



CINGO M8.3TD EVO

 **MERLO**

PERFORMANCE AND FEATURES

CINGO M8.3TD EVO Multifunction

PERFORMANCE

Capacity:

800 kg

Engine:

Kubota Diesel Z602 – 12.5 kW / 17 HP – 2 cylinders

Starting:

Electrical

Engine cooling:

Liquid-type

Maximum speed:

4 km/h

Track:

Fixed

Maximum longitudinal gradient:

35%

Maximum cross slope:

20%

TRANSMISSION AND HYDRAULIC SYSTEM

Transmission:

Hydrostatic-type, with axial piston pumps in tandem with planetary gearmotors

Transmission pumps:

2 x 38 litres/min

Drive levers:

Hydraulic servo controls

Service pump:

8 + 2.5 cc (double pump)

Auxiliary circuit oil flow rate:

27 + 8 l/min

Auxiliary service lines:

1 auxiliary service line (in and out) with hook to supply fluid continuously to the 1-lever distributor
3 auxiliary service lines (in and out) of which one with hook to supply fluid continuously to the 4-lever distributor

Auxiliary circuit max. pressure:

180 bar

Multifunction (Merlo patent):

Yes

WEIGHT AND DIMENSIONS

Machine weight:

510 kg

Width:

800 mm

Length:

1,650 mm (with folded operator platform)

Maximum height:

1,124 mm

- not available. ● standard. ○ optional.

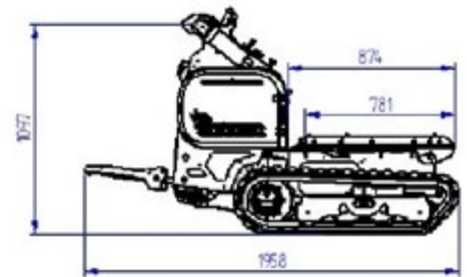
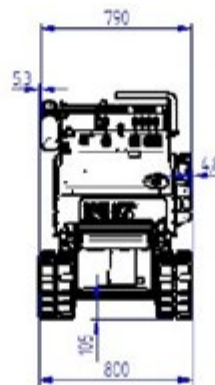
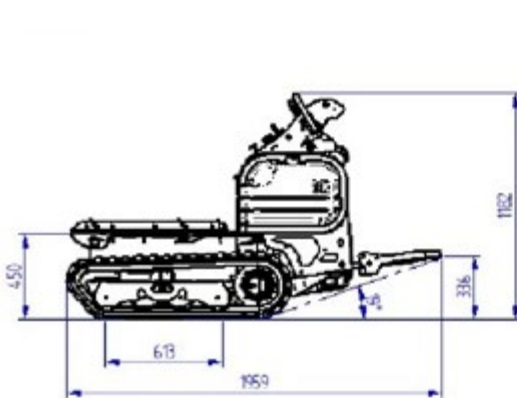

MERLO S.P.A.

Via Nazionale, 9
12010 S. Defendente di Cervasca
(Cuneo) Italy

Tel. +39 0171614111

Fax +39 0171684101

info@merlo.com

www.merlo.com

Data, characteristics and illustrations contained in this document are indicative and not binding. Merlo Spa pursues a policy of continuous research and development, therefore, our products may have different characteristics from those described or may undergo changes without any prior notice. The products shown may include optional equipment

Your Merlo dealer

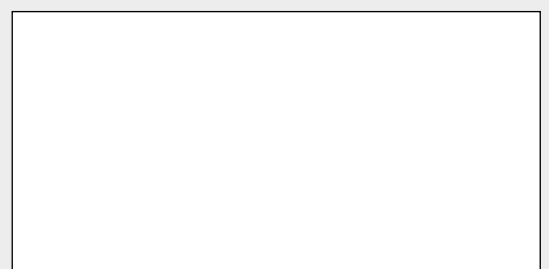

cingom8tdevo_0322_ENG