



CINGO M700TD



PERFORMANCE AND FEATURES

CINGO M700TD Tracked Carrier

PERFORMANCE

Capacity:	700 kg
Engine:	Honda Petrol GX390 - 8.7 kW / 12 HP
Starting:	Electrical
Engine cooling:	Air
Maximum speed:	2.5 – 4 km/h
Track:	Fixed
Maximum longitudinal gradient:	35%
Maximum cross slope:	20%

TRANSMISSION AND HYDRAULIC SYSTEM

Transmission:	Hydraulic-type, with gear pumps in tandem with planetary gearmotors
Transmission pumps:	2 x 14 litres/min
Drive levers:	Hydraulic systems
Service pump:	6 cc
Auxiliary circuit oil flow rate:	20 l/min
Auxiliary service lines:	2 auxiliary service lines (in and out) Option available on request: Auxiliary service line kit (CV315)
Auxiliary circuit max. pressure:	180 bar
Multifunction (Merlo patent):	No
Multifunction tracked carrier	Yes

WEIGHT AND DIMENSIONS

Machine weight:	480 kg
Width:	750 mm
Length:	1640 mm (with folded operator platform)
Maximum height:	1,245 mm

- not available. ● standard. ○ optional.

Procedure for replacing attachments:

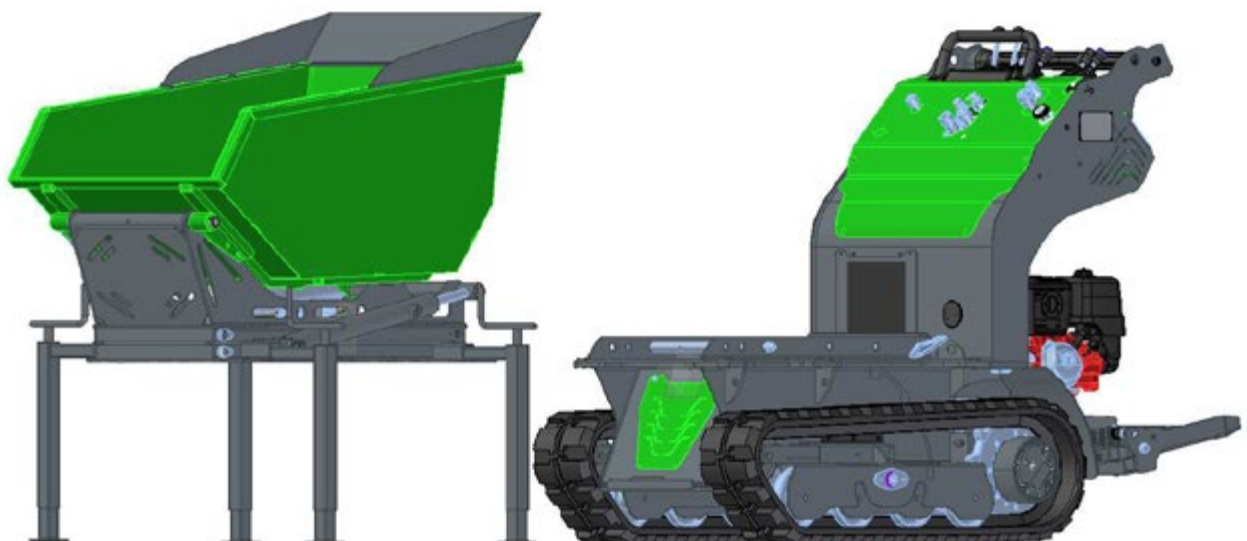

Dimensions with standard dumper body:

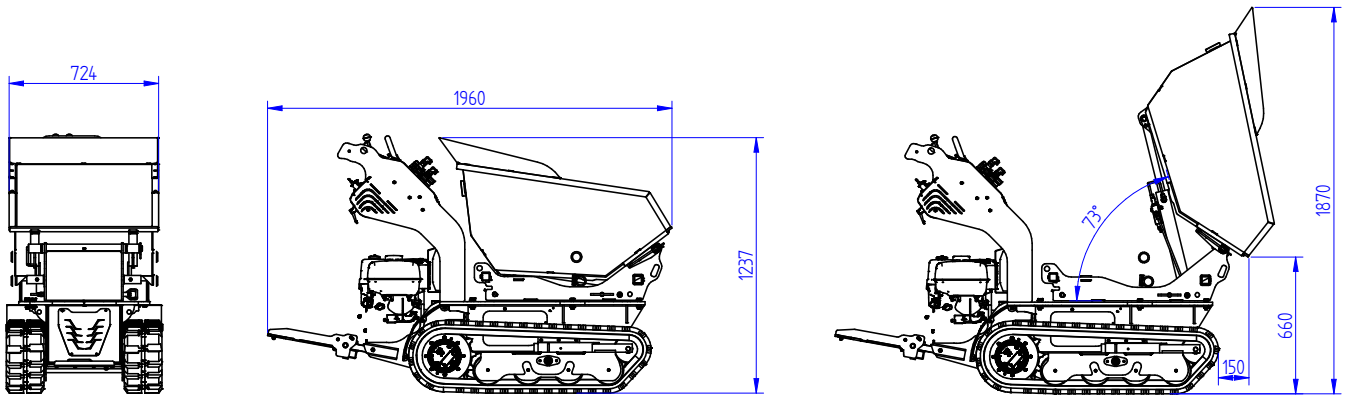

Dimensions with standard dumper body and self-loading bucket:

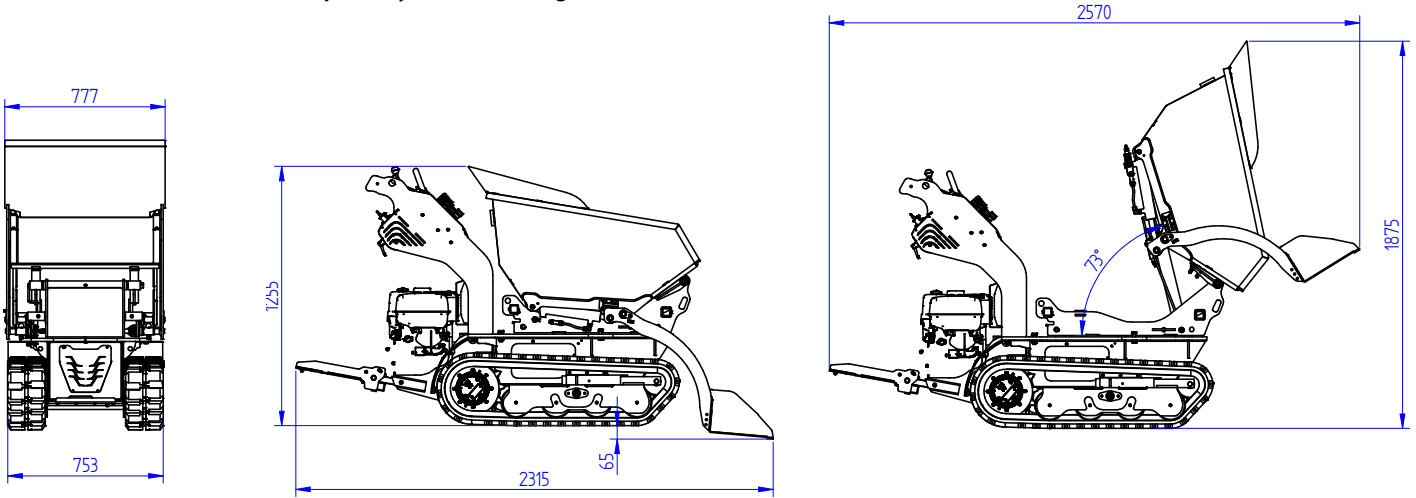

Dimensions with self-loading concrete mixer

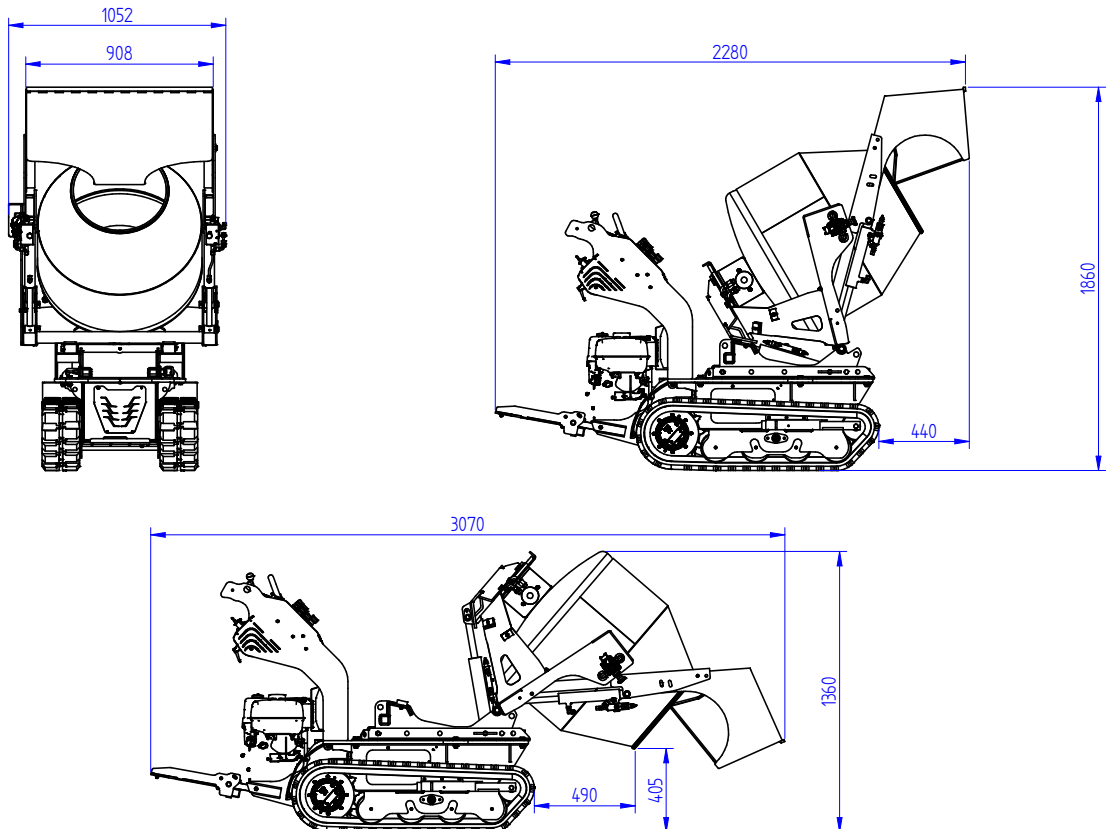

Dimensions with farm dumper body:

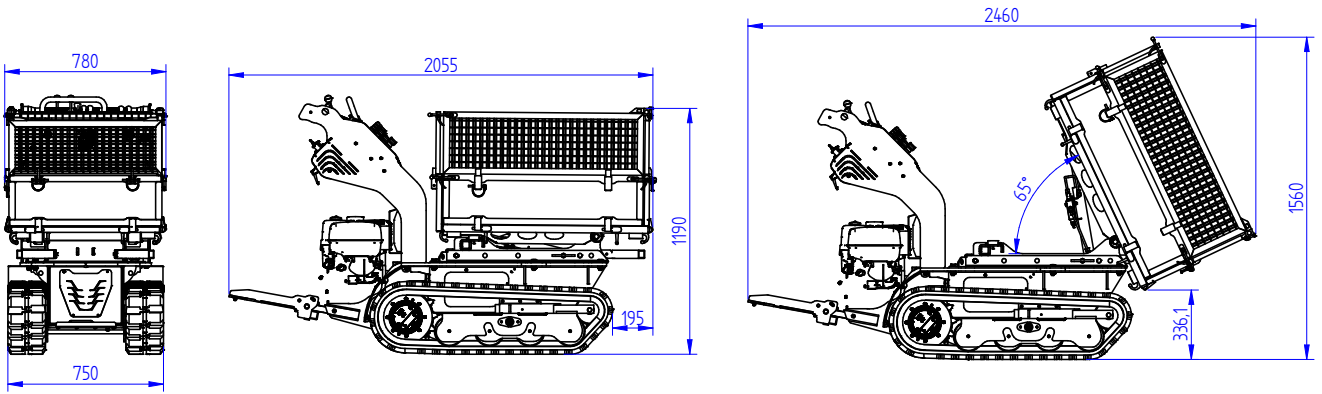

Dimensions with pantograph

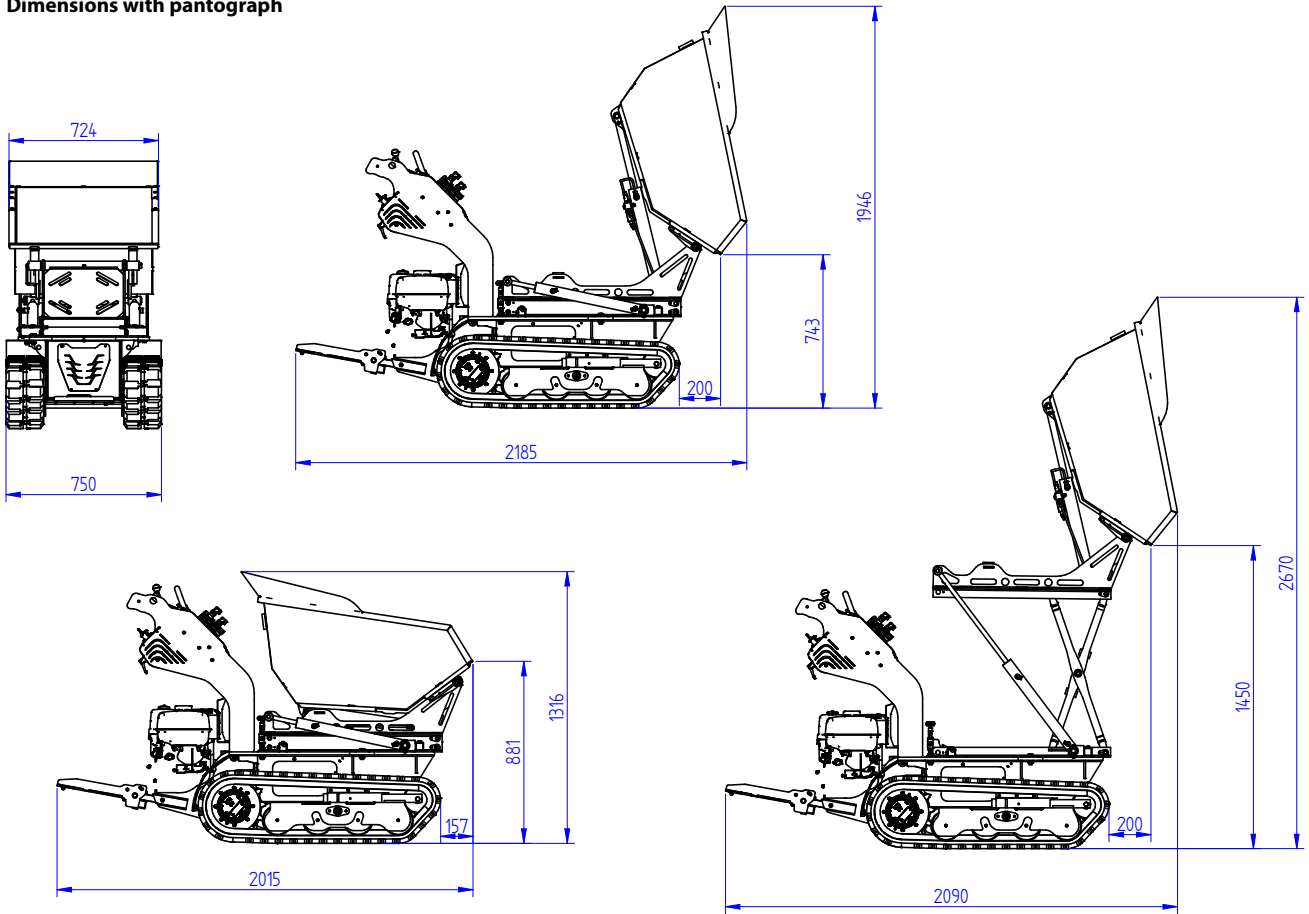

MERLO S.P.A.
 Via Nazionale, 9
 12010 S. Defendente di Cervasca
 (Cuneo) Italy
 Tel. +39 0171614111
 Fax +39 0171684101

info@merlo.com
www.merlo.com

Data, characteristics and illustrations contained in this document are indicative and not binding. Merlo Spa pursues a policy of continuous research and development, therefore, our products may have different characteristics from those described or may undergo changes without any prior notice. The products shown may include optional equipment

Your Merlo dealer

