



# CINGO M500



**MERLO**

## PERFORMANCE AND FEATURES

## CINGO M500 Tracked Carrier

### PERFORMANCE

Capacity:

500 kg

Engine:

Honda Petrol GX200 - 4.1 kW / 5.5 HP

Starting:

Manual

Engine cooling:

Air

Maximum speed:

3.5 km/h

Track:

Fixed

Maximum longitudinal gradient:

35%

Maximum cross slope:

20%

### TRANSMISSION AND HYDRAULIC SYSTEM

Transmission:

Hydraulic with gear pumps and orbital motors on each track and overcenter valve

Transmission pumps:

2 x 11.5 litre/min - Maximum operating pressure 150 bar

Drive levers:

Hydraulic systems

Parking brake:

Manual

Service pump:

-

Auxiliary circuit oil flow rate:

-

Auxiliary service lines:

1 auxiliary service line (in and out)

Auxiliary circuit max. pressure:

-

Multifunction (Merlo patent):

No

Multifunction tracked carrier

No

### WEIGHT AND DIMENSIONS

Machine weight:

M500D (with dumper body): 191 kg  
M500DP (with dumper body and self-loading bucket): 227 kg  
M500C (with farm dumper body): 210 kg

Width:

690 mm

Length:

M500D/DP: 1416 mm - M500C: 1,471 mm

Maximum height:

1,126 mm

Dumper body capacity when full

M500D/DP: 160 litres - M500C: 124 litres

#### Main dimensions of the various submodels:

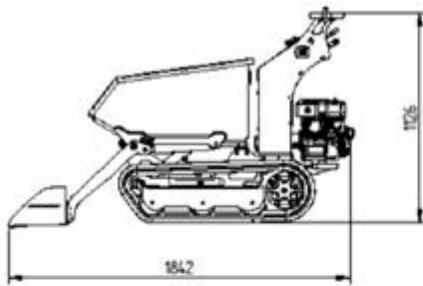

M500DP

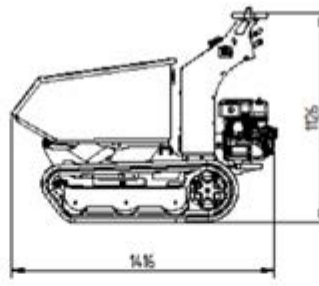

M500D

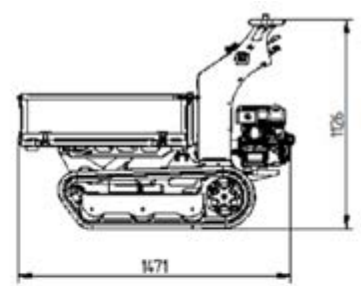

M500C

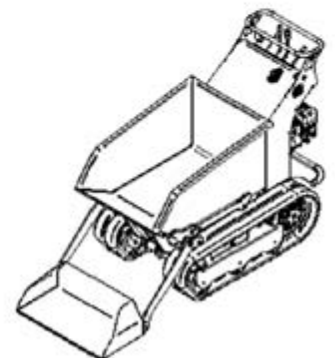
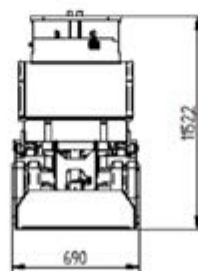
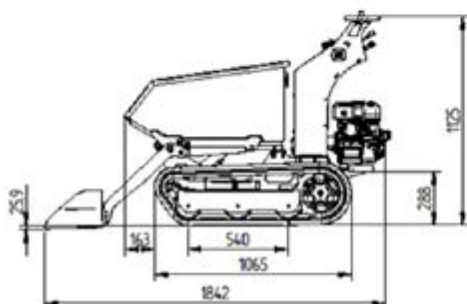



**Comfortable driving seat  
easy to manoeuvre**

**Hydraulic  
front tilting**

**Easy access for  
inspection and maintenance**

**Approach angle of  
track to overcome any  
obstacle**

**Sturdy and  
very solid chassis**

**High quality Honda petrol  
engine with convenient pull  
start and reduced noise  
emissions in compliance with  
regulatory limits. Mounted  
on vibration dampers, which  
significantly reduce vibrations.**

**Hydraulic transmission  
with overcenter valve**



**Hour counter  
(option on request)**



Data, characteristics and illustrations contained in this document are indicative and not binding. Merlo Spa pursues a policy of continuous research and development, therefore, our products may have different characteristics from those described or may undergo changes without any prior notice. The products shown may include optional equipment

**MERLO S.P.A.**  
Via Nazionale, 9  
12010 S. Defendente di Cervasca  
(Cuneo) Italy  
Tel. +39 0171614111  
Fax +39 0171684101

**info@merlo.com**  
**www.merlo.com**

**Your Merlo dealer**

