



CINGO M12.3EVO

 **MERLO**

PERFORMANCE AND FEATURES

CINGO M12.3EVO Multifunction

PERFORMANCE

Capacity:
 Engine:
 Starting:
 Engine cooling:
 Maximum speed:
 Track:
 Maximum longitudinal gradient:
 Maximum cross slope:

1200 kg
 Kubota Diesel D722 – 14.9 kW / 21 HP – 3 cylinders
 Electrical
 Liquid-type
 5 km/h
 Fixed
 35%
 20%

TRANSMISSION AND HYDRAULIC SYSTEM

Transmission:
 Transmission pumps:
 Drive levers:
 Service pump:
 Auxiliary circuit oil flow rate:
 Auxiliary service lines:

Hydrostatic-type, with axial piston pumps in tandem with planetary gearmotors
 2 x 45 litres/min
 Hydraulic servo controls
 8 + 2.5 cc (double pump)
 27 + 8 l/min
 1 auxiliary service line (in and out) with hook to supply fluid continuously to the 1-lever distributor
 3 auxiliary service lines (in and out) of which one with hook to supply fluid continuously to the 4-lever distributor

Auxiliary circuit max. pressure:
 Multifunction (Merlo patent):

200 bar
 Yes

WEIGHT AND DIMENSIONS

Machine weight:
 Width:
 Length:
 Maximum height:

720 kg
 1,000 mm
 1820 mm (with folded operator platform)
 1,240 mm

- not available. ● standard. ○ optional.

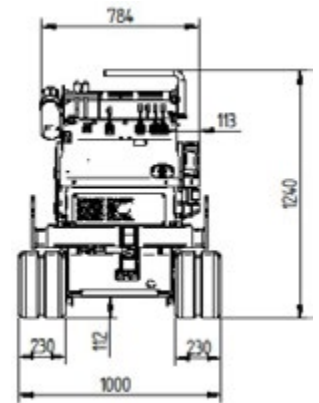
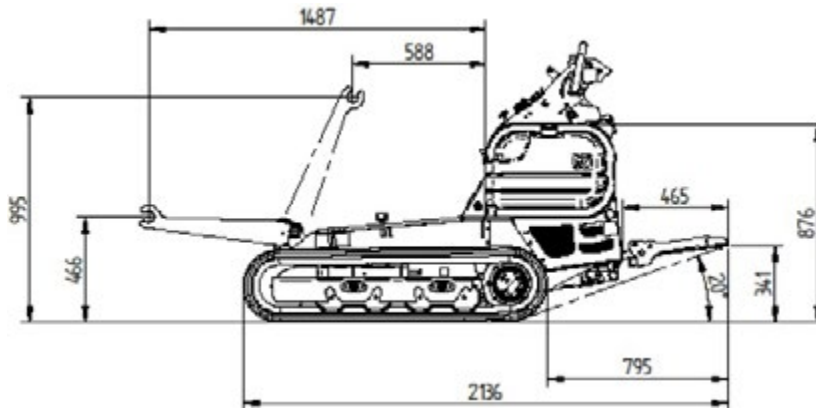

Data, characteristics and illustrations contained in this document are indicative and not binding. Merlo Spa pursues a policy of continuous research and development, therefore, our products may have different characteristics from those described or may undergo changes without any prior notice. The products shown may include optional equipment

MERLO S.P.A.
 Via Nazionale, 9
 12010 S. Defendente di Cervasca
 (Cuneo) Italy
 Tel. +39 0171614111
 Fax +39 0171684101

Your Merlo dealer

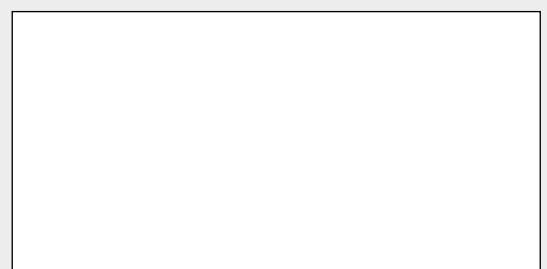

info@merlo.com
www.merlo.com