

Kubota

- U.S.A. : **KUBOTA TRACTOR CORPORATION**
3401 Del Amo Blvd., Torrance, CA 90503, U.S.A.
Telephone : (310)370-3370
- Western Division : 1175 S. Guild Av., Lodi, CA 95240
Telephone : (209)334-9910
- Central Division : 14855 FAA Blvd., Fort Worth, TX 76155
Telephone : (817)571-0900
- Northern Division : 6300 at One Kubota Way, Groveport, OH 43125
Telephone : (614)835-1100
- Southeast Division : 1025 Northbrook Parkway, Suwanee, GA 30024
Telephone : (770)995-8855
- Canada : **KUBOTA CANADA LTD.**
5900 14th Avenue, Markham, Ontario, L3S 4K4, Canada
Telephone : (905)294-7477
- Richmond Distribution Center : 2620 Viscount Way, Richmond, B.C. V6V 1N1
Telephone : (604)270-9286
- Drummondville Distribution Center : 5705 Place Kubota, Drummondville, Québec, J2B 6B4
Telephone : (819)478-7151
- France : **KUBOTA EUROPE S.A.S**
19-25, Rue Jules Vercurysse, Z.I. BP88, 95101 Argenteuil Cedex, France
Telephone : (33)1-3426-3434
- Italy : **KUBOTA EUROPE S.A.S Italy Branch**
Via Grandi, 29 20068 Peschiera Borrome (MI) Italy
Telephone : (39)02-51650377
- Germany : **KUBOTA BAUMASCHINEN GmbH**
Steinhauser str, 100, 66482 Zweibrucken Rheinlandpfalz Germany
Telephone : (49)6332-4870100
- U.K. : **KUBOTA (U.K.) LTD.**
Dormer Road, Thame, Oxfordshire, OX9 3UN, U.K.
Telephone : (44)1844-214500
- Australia : **KUBOTA TRACTOR AUSTRALIA PTY LTD.**
25-29 Permas Way, Truganina, VIC 3029, Australia
Telephone : (61)-3-9394-4400
- Malaysia : **SIME KUBOTA SDN. BHD.**
No.3 Jalan Sepadu 25/123 Taman Perindustrian Axis,
Seksyen 25, 40400 Shah Alam, Selangor Darul Ehsan Malasia
Telephone : (60)3-736-1388
- Philippines : **KUBOTA AGRO-INDUSTRIAL MACHINERY PHILIPPINES, INC.**
155 Panay Avenue, South Triangle Homes, 1103 Quezon City, Philippines
Telephone : (63)2-9201071
- Taiwan : **SHIN TAIWAN AGRICULTURAL MACHINERY CO., LTD.**
16, Fengping 2nd Rd, Taliaw Shiang Kaohsiung 83107, Taiwan R.O.C.
Telephone : (886)7-702-2333
- Indonesia : **P.T. KUBOTA INDONESIA**
JALAN. Setyabudi 279, Semarang, Indonesia
Telephone : (62)-24-7472849
- Thailand : **THE SIAM KUBOTA INDUSTRY CO., LTD.**
101/19-24 Navanakorn, Tambol Klongneung, Amphur Klongluang, Pathumtani 12120, Thailand
Telephone : (66)2-529-0363
- Japan : **KUBOTA Corporation**
Farm & Industrial Machinery International Operations Headquarters
2-47, Shikitsuhigashi 1-chome, Naniwa-ku, Osaka, Japan 556-8601

English (Australia)
Code No. RB548-8134-6

OPERATOR'S MANUAL

KUBOTA EXCAVATOR

Super Series **T4**
TIER

MODEL **U25**

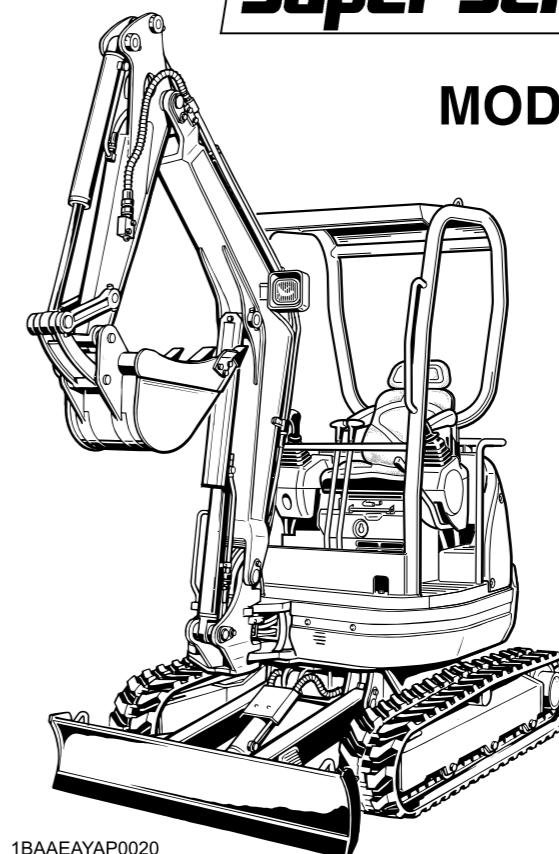

1BAAEAYAP0020

U
2
5

READ AND SAVE THIS MANUAL

















Kubota

LIST OF ABBREVIATION

Abbreviations	Description
API	American Petroleum Institute
ASTM	American Society for Testing and Materials, USA
CECE	Committee for European Construction Equipment
DIN	German Institute for Standards, Federal Republic of Germany
EN	European Standard
FOPS	Falling Object Protective Structures
FRONT	"Front" means the front view towards the boom and dozer
Hi	High speed
ISO	International Standardization Organization
JIS	Japanese Industrial Standard
L	Volume (Liter)
L/min	Liter per minute
Lo	Low speed
MIL	Military Standards
rpm	Revolutions per minute
ROPS	Roll-Over Protective Structures
SAE	Society of Automotive Engineers, USA
TPSS	Two Pattern Selection System

GENERAL SYMBOLS

The instruments and operation elements have been marked with a series of symbols in order to simplify the operation of your excavator. These symbols are listed below with the respective descriptions.

	Safety alert Symbol		Boom swing (left)
	Alarm lamp "Fuel level too low"		Boom swing (Right)
	Alarm lamp "Engine Oil pressure "		Dozer raise
	Alarm lamp "Battery charge"		Dozer lower
	Horn		Operation direction of control lever
	Diesel		Operation direction of control lever
	Hydraulic fluid		Read operator's manual
	Fast		Lock
	Slow		Unlock
	Excavator - Overhead movement toward the front		
	Excavator - Overhead movement toward the rear		
	Boom up		
	Boom down		
	Arm up		
	Arm lower		
	Bucket in		
	Bucket dig / rollback		
	Wiper/Washer switch		

FOREWORD

You are now the proud owner of a KUBOTA excavator. This excavator is a product of KUBOTA quality engineering and manufacturing. It is made of the fine materials and under rigid quality control systems. It will give you long, satisfactory service. To obtain the best use of your excavator, please read this manual carefully. It will help you become familiar with the operation of the excavator and contains many helpful hints about excavator maintenance. It is KUBOTA's policy to utilize as quick as possible every advance in our research. The immediate use of new techniques in the manufacture of products may cause some small parts of this manual to be outdated. KUBOTA distributors and dealers will have the most up-to-date information. Please do not hesitate to consult with them.

SAFETY FIRST

This symbol, the industry's "Safety Alert Symbol", is used throughout this manual and on labels on the machine itself to warn of the possibility of personal injury. Read these instructions carefully. It is essential that you read the instructions and safety regulations before you attempt to assemble or use this unit.

 **DANGER :** Indicates an imminently hazardous situation which, if not avoided, will result in death or serious injury.

 **WARNING :** Indicates a potentially hazardous situation which, if not avoided, could result in death or serious injury.

 **CAUTION :** Indicates a potentially hazardous situation which, if not avoided, may result in minor or moderate injury.

IMPORTANT : Indicates that equipment or property damage could result if instructions are not followed.

NOTE : Gives helpful information.

CONTENTS

▲SAFE OPERATION	1
DEALER SERVICE.....	1
TECHNICAL DATA.....	2
DESCRIPTION OF MACHINE PARTS.....	3
INSTRUMENT PANEL AND CONTROL ELEMENTS.....	4
CHECKS BEFORE START	6
DAILY CHECKS.....	6
SLIDING THE SEAT	6
OPENING AND CLOSING OF PARTS.....	7
Opening / Closing of the Engine Bonnet.....	7
Opening and Closing of the Fuel Tank Cover.....	7
Keeping the Tools.....	8
Operator's Manual Storage.....	8
HANDLING THE SAFETY DEVICES.....	8
Control Lever Lock.....	8
Roll-Over Protective Structures (ROPS) / Falling-Objective Protective Structures (FOPS)	9
OPERATION OF THE ENGINE.....	11
STARTING THE ENGINE	11
Display Selector Switch	12
Charge Lamp	12
Oil Lamp	12
Glow Lamp.....	12
LCD Display for Normal Operation	13
LCD Display for Warning	14
Warning Lamp	14
Checkpoints after Starting the Engine	15
STARTING THE ENGINE UNDER COLD CONDITIONS.....	15
STOPPING THE ENGINE.....	15
Engine Stop Lever	16
STARTING WITH AN AUXILIARY BATTERY	16
Observe Following Guidelines when Starting with an Auxiliary Battery.....	16
EXCAVATOR OPERATION	18
RUNNING-IN OF THE NEW EXCAVATOR.....	18
Do not Work with Full Engine Rpm's or Full Loads during the First 50 Working Hours..	18
Oil Change in the Run-in Stage	18
Seat Belt	18
STARTING	18
Adjusting the Operator's Seat.....	18
Lock Lever	19
Working Light Switch	19
Travel Buzzer.....	19
TWO PATTERN SELECTION SYSTEM(TPSS).....	20

Pattern Change.....	20
OPERATION OF THE BOOM.....	21
OPERATION OF THE ARM.....	21
OPERATION OF BUCKET	22
SWIVEL(UNIT SWING)OPERATION	22
BOOM SWING OPERATION.....	23
OPERATION OF THE DOZER	23
SERVICE PORT OPERATION	24
DRIVING	25
Drive Levers (Right, Left).....	25
Travel Speed Switch.....	26
TURNS.....	27
Pivot Turn	27
Spin Turn	28
UP AND DOWNHILL TRAVELLING	28
PARKING ON A SLOPE	29
IMPORTANT INFORMATION ON EXCAVATOR OPERATION	29
TRANSPORTING THE EXCAVATOR ON A TRUCK.....	30
LIFTING OF THE EXCAVATOR.....	32
MAINTENANCE.....	34
MAINTENANCE INTERVALS	34
DAILY CHECKS.....	37
Check Fuel Level.....	37
Check Engine Oil Level	38
Check Hydraulic Oil Level.....	38
Checking Coolant Level.....	39
Lubrication Points	39
Check Fan Belt	40
Check Radiator and Oil cooler.....	40
Cleaning of Engine and Electrical Wiring.....	41
Washing Whole Machine	41
REGULAR CHECKS AND MAINTENANCE WORK	42
EVERY 50 SERVICE HOURS	42
Draining Fuel Tank	42
Draining Water Separator.....	42
Battery	43
Battery Charging.....	44
Greasing of Swing Bearing Teeth.....	44
EVERY 200 SERVICE HOURS	45
Checking Fan Belt Tension.....	45
Checking Radiator Hoses and Clamps.....	45
Inspection and Cleaning Air Filter Element.....	46
Air Filter Maintenance.....	46
Greasing Swing Bearing	46
Checking Fuel Line and Intake Air Line.....	47
EVERY 250 SERVICE HOURS	47
Engine Oil Change (First Engine Oil Change after 50 Service Hours).....	47
Replacing Engine Oil Filter(First Engine Oil Filter Change after 50 Service Hours).....	48
Lubrication of the Pilot Valve	49

EVERY 500 SERVICE HOURS	49
Drive unit Oil Change(First Oil Change at 100 hours)	49
Replacing Fuel Filter Cartridge	50
Replacing Hydraulic Return Filter Element(first replacement after 250 service hours) ..	50
EVERY 1000 SERVICE HOURS	51
Cleaning of the Pipe filter of the Hydraulic Pilot System (for Hydraulic Pilot Types)	51
Replacing the Hydraulic Pilot Filter Element.....	51
Hydraulic Oil Change (Including Replacing of the Suction Filter in the Hydraulic Tank) ..	52
Hydraulic Oil Check with Hydraulic Breakers	53
EVERY 1000 SERVICE HOURS OR ONCE A YEAR	53
Replacing Air Filter Element	53
EVERY 1500 SERVICE HOURS	53
Checking Fuel Injection Nozzle(Injection Pressure)	53
EVERY 2000 SERVICE HOURS	53
Changing Front Idler and Track Roller Oil	53
Checking the Alternator and Starter Motor	53
EVERY 3000 SERVICE HOURS	53
Checking Injection Pump	53
ANNUAL SERVICING	54
Electrical Wiring and Fuses	54
Checking the Electrical Circuit	54
BIENNIAL SERVICING	54
Replacement of Radiator Hoses.....	54
Changing Radiator Coolant	54
Replacing Fuel Hose	55
Replacing Intake Air line	55
OTHER ADJUSTMENTS AND REPLACEMENTS.....	56
PURGING OF THE FUEL SYSTEM	56
ADJUSTMENT OF TRACKS	56
Special Information when Using Rubber Tracks.....	57
CHANGING THE BUCKET	58
FUSES	58
Replacing Fuses.....	58
Fuse Capacities and Circuits	58
Slow Blow Fuse	59
TROUBLESHOOTING.....	60
KUBOTA I.C.S. NAVIGATION LIST OF MESSAGES	61
OPERATION UNDER COLD WEATHER CONDITIONS	63
PREPARATION FOR OPERATION IN COLD WEATHER.....	63
PROCEDURE AFTER DONE WORK.....	63
LONG STORAGE	64
RECOMMENDED OILS.....	66
MAIN DIMENSIONS	67
LIFTING CAPACITY	68

SAFE OPERATION

The best insurance against accidents is to abide by the safety regulations.

Read and understand this section carefully, before operating the excavator.

Every user, however experienced, should carefully read and understand this section and those of the attachments and accessories before taking the excavator into operation. The owner is obliged to inform the operators of these instruction in detail.

Keep this manual in the storage place. (See "Operator's Manual Storage" in "CHECKS BEFORE START" section.)

1. BEFORE OPERATION

1. Make yourself acquainted with the excavator and be aware of its limits. Read the operating instructions carefully before starting the excavator.
2. Obey the danger, warning and caution labels on the machine.
3. For your safety, ROPS/FOPS (Roll-Over Protective Structures, Falling Objects Protective Structures.) with a seat belt is installed by KUBOTA. Always use the seat belt when the machine is equipped with a ROPS/FOPS.
Do not modify structural members of ROPS by welding, drilling, bending, grinding or cutting, as this may weaken the structure. If any component is damaged, replace it. Do not attempt repairs. If ROPS is loosened or removed for any reason, make sure all parts are reinstalled correctly. Tighten mounting bolts to proper torque.
4. The seat belt must be inspected regularly and replaced if damaged.

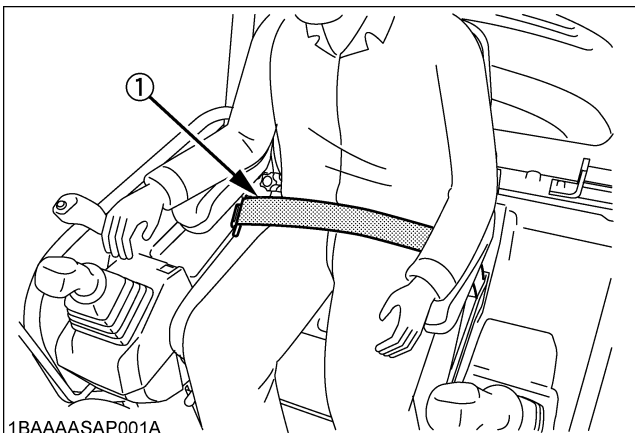

(1) Seat belt

5. Always sit in the operator's seat when starting engine or operating levers or controls.

6. Study control lever pattern A and pattern B. Then choose the one which is most familiar. Familiarize yourself with the pattern selected by operation slowly at low engine speed.
 - Engage the lever lock to prevent accidental pattern change.

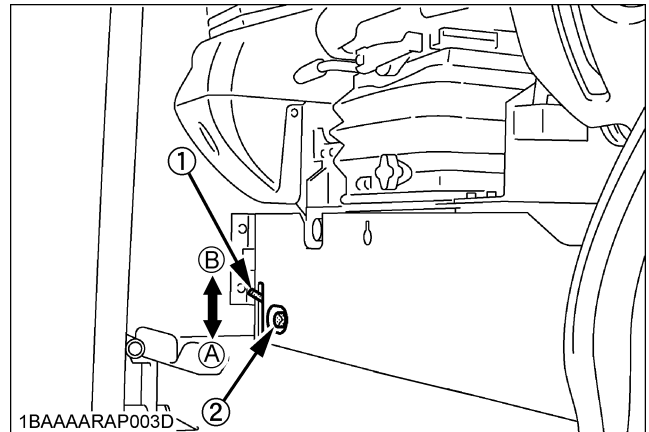

- (1) Pattern selector lever
(Two Pattern Selection System:TPSS)
- (2) Lever lock knob

7. Do not operate the excavator while under the influence of alcohol, medication, controlled substances or while fatigued.
8. Check the surroundings carefully before using the excavator or when attachments are being attached.
 - Pay attention to the overhead clearance with electric wires.

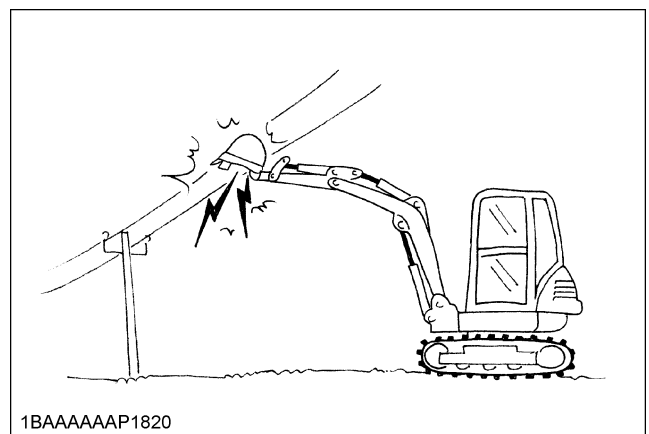

1BAAAAAP1820

- Check for pipes and buried cables before digging.
- Check for hidden holes, hindrances, soft underground, and overhangs.

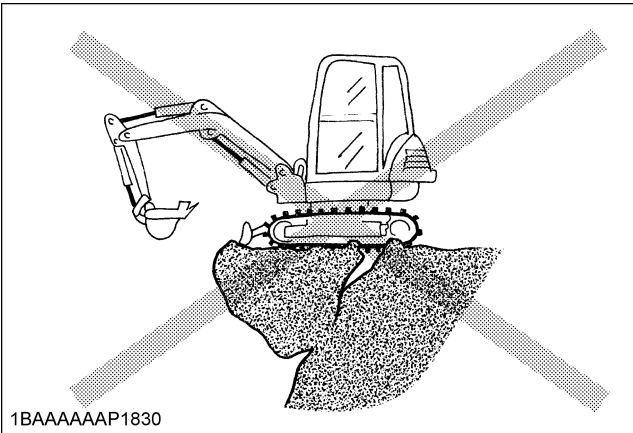

- During excavator use, do not allow any persons within the working range.
9. Do not allow other persons to use the machine before having informed him on the exact operation and work instructions, and be assured that the operator's manual has been read and completely understood.
 10. Do not wear baggy, torn or oversized clothing when working with the excavator. Clothing can get caught in rotating parts or control elements which can cause accidents or injuries. Wear adequate safety clothing, e.g. safety helmet, safety shoes, eye protection, ear protection, working gloves, etc., as necessary and as prescribed by law or statutes.

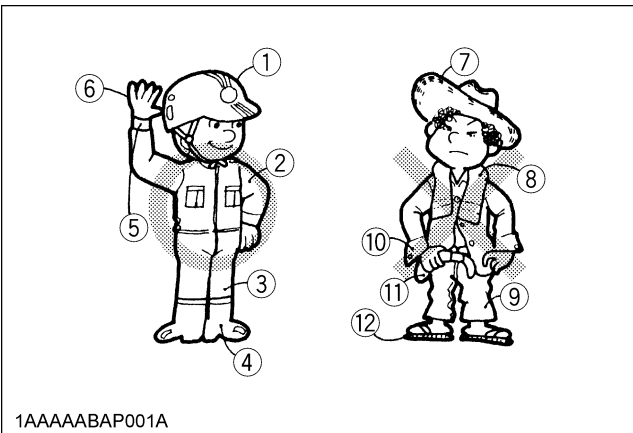

- | | |
|---------------------------|-------------------------------|
| (1) Helmet | (7) Straw hat |
| (2) Clothing fit for work | (8) Towel |
| (3) Tight seams | (9) Baggy trousers |
| (4) Good grip footwear | (10) Loose cuffs of the shirt |
| (5) Well fitting cuffs | (11) Baggy shirt |
| (6) Working gloves | (12) Rubber sandals |

11. Do not allow passengers to ride on any part of the excavator at anytime. The operator must remain in the excavator seat during operation.
12. Check mechanical parts for correct adjustments and wear.
13. Keep your excavator clean. Heavy soiling, grease, dust and grass can cause fires, accidents or injuries.
14. Use only KUBOTA authorized attachments.
15. Before starting the excavator, be absolutely sure that the excavator has been filled with fuel, lubricated, greased and undergone all necessary maintenance.
16. Do not modify the excavator, otherwise it could lead to unforeseen safety problems.
17. Do not hammer anything that is above the operator's seat level. Objects may fall into the operator station of mini-excavator from front.
18. Make sure attachments, particularly those utilizing quick attach systems, are securely mounted.

2. STARTING OF THE EXCAVATOR

1. Get into and out of the machine safely. Always face the machine. Always use handrails and available steps and keep yourself well balanced. Do not hold any of the control levers and switches. Do not jump on or off the machine, whether stationary or in motion.
2. Start and control the excavator only from the operator's seat. The driver should not lean out of his seat when the engine is running.
3. Before starting the engine, make sure that lock levers are in position "Lock" and all control levers and pedals are in their neutral positions and the seat belt is fastened correctly.
4. Make sure that the dozer blade is in front of you. (The dozer must be raised.) If the levers are activated with the dozer blade at the rear, the tracks will move in the opposite direction of the drive levers.

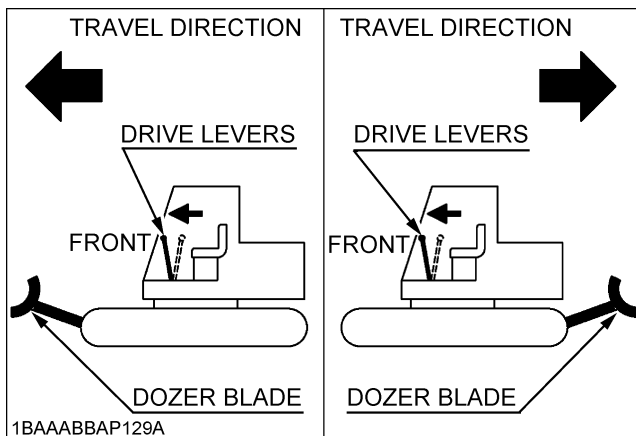

5. Do not operate or idle engine in a non-ventilated area. Carbon monoxide gas is colorless, odorless, and deadly.

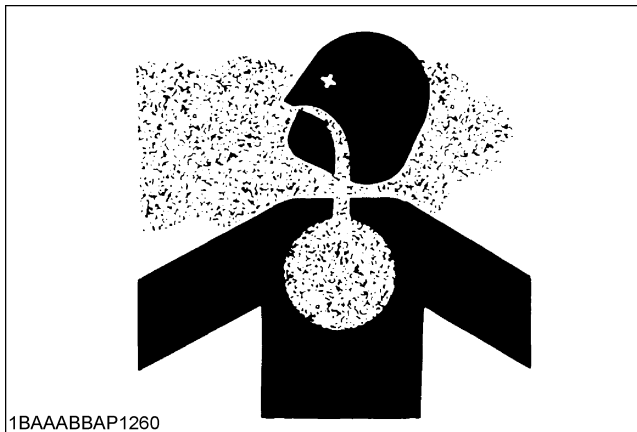

6. Keep all safety equipment and covers in place. Replace damaged or missing safety devices.

7. Precautions against tipping over. Keep away from steep slopes and embankments. Do not swing the bucket downhill. Lower the dozer during digging. Keep the bucket as low as possible while driving uphill. Turn slowly on slopes (at reduced speed). Do not place the excavator near the edges of trenches and banks, as the earth can give away due to the weight of the excavator.

ALLOWABLE CLIMBING ANGLE : 36 % (20 deg.)
ALLOWABLE ANGLE IN CASE OF CROSSING
SIDEWAY : 27 % (15 deg.)

8. Watch out at all times for the area to which the excavator is being moved. Pay attention to any hindrances.
9. Keep enough distance from trench and bank edges.

◆ Safety for children

Tragedy can occur if the operator is not alert to the presence of children. Children generally are attracted to machines and the work they do.

1. Never assume that children will remain where you last saw them.
2. Keep children out of the work area and under the watchful eye of another responsible adult.
3. Be alert and shut your machine down if children enter the work area.
4. Never carry children on your machine. There is not a safe place for them to ride. They may fall off and be run over or interfere with your control of the machine.
5. Never allow children to operate the machine even under adult supervision.
6. Never allow children to play on the machine or on the attachments.
7. Use extra caution when backing up. Look behind and down to make sure the area clear before moving.
8. When parking your machine, if at all possible, park on a firm, flat and level surface; if not, park across a slope. Lower the bucket and dozer to the ground, remove the key, place the control lock levers in the locked position from the ignition and lock the cab door (if equipped), before you leave.

3. AFTER OPERATION

Before leaving the machine,

- Park the excavator on a firm, flat and level surface.
- Lower the attachments and the dozer blade to the ground.
- Stop the engine.
- Release pressure trapped in the hydraulic system.
- Lock all control levers.
- Remove the key.

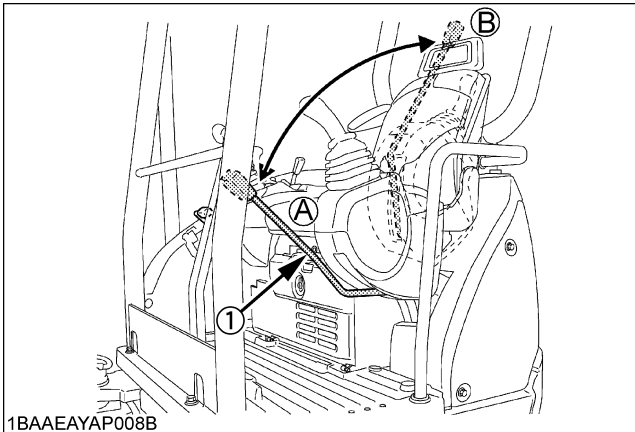
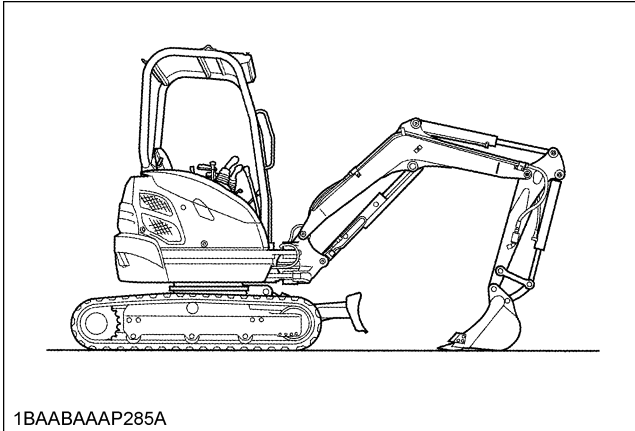

(1) Lock lever for control lever (A) "Unlock"
(B) "Lock"

4. SAFE LOADING AND TRANSPORT OF THE EXCAVATOR

1. Observe all regulations concerning the transport of excavators on public roads.
2. Use adequately long and robust ramps when loading on the machine. (for details see "TRANSPORTING THE EXCAVATOR ON A VEHICLE")
3. Do not change the running direction and to avoid a tipping over, do not try to swing the attachment crosswise to the loading ramps.
4. Lower the attachment on the loading bed and release the pressure from the hydraulic system.
After loading the excavator on the truck, block the tracks with blocks and cable down the excavator.

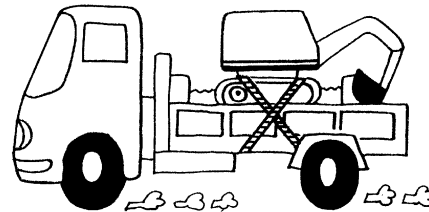

5. Avoid abrupt braking of the vehicle with the excavator loaded. Sudden braking cause the excavator to move and may cause a serious accident.
6. If the excavator is to tow another machine, make sure the load is smaller than the strength of the hook, tow chain or cable.

Max. drawbar pull at coupling hook	70450 N (7184 kgf)
Max. vertical load at coupling hook	7210 N (735 kgf)

7. Do not use hooks on the roof of canopy or CAB for lifting the excavator.

5. MAINTENANCE

Before doing maintenance work on the excavator, place the machine on even solid ground, lower the attachments to the ground, stop the engine and remove the key. When dismantling hydraulic parts, make sure that the hydraulic oil has cooled down sufficiently to avoid burns. Start maintenance work carefully, e.g. loosen plug slowly so that oil will not squirt out.

1. Before doing work on the engine, the exhaust system, the radiator and the hydraulics, let the excavator cool down sufficiently.
2. Turn off the engine at all times when filling with fuel. Avoid spilling and over-filling of fuel.

3. Smoking is prohibited while refueling or handling the battery. Keep sparks and fire away from the fuel tank and battery. Flammable gases escape from the battery, especially during charging.
4. Do not use or charge the refillable type battery if the fluid level is below the LOWER (lower limit level) mark. Otherwise, the battery component parts may be prematurely deteriorated, which may shorten the battery's service life or cause an explosion. Check the fluid level regularly and add distilled water as required so that the fluid level is between the UPPER and LOWER levels.
5. Read and follow the directions "STARTING WITH AN AUXILIARY BATTERY" in "OPERATION OF THE ENGINE", when starting with an auxiliary battery.
6. Keep a first-aid box and a fire extinguisher at hand at all times.
7. Do not open the radiator cap before the radiator has cooled down sufficiently
First loosen the cap to the first stop and allow the system enough time to release the remaining pressure. Then loosen the cap completely.
8. To avoid short-circuiting the battery, always remove the ground cable first and attach the positive cable first.
9. Leaking hydraulic fluid has enough pressure to penetrate the skin and cause serious injuries. Leakages from pin holes can be totally invisible. Do not use hands for checking for leaks. Always use a piece of wood or cardboard. It is strongly recommended to use a face mask or eye protection. Should injuries occur with leaking hydraulic fluid, contact a doctor immediately. This fluid can cause gangrene or serious allergic reactions.

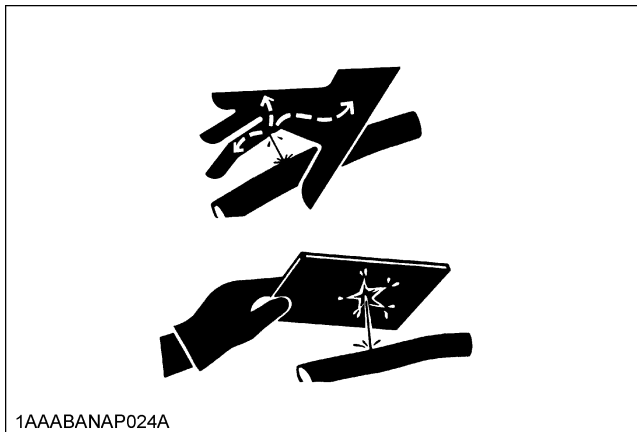

10. To avoid environmental damage from acid and heavy metals, do not throw the battery away.
11. Observe all laws and regulations concerning the disposal of used oil, coolants, solvents, hydraulic fluids, battery acids and batteries.
12. To avoid fire, do not heat the hydraulic components (tanks, pipes, hoses, cylinders) before they have been drained and washed.

13. Use a face mask or eye protection to protect the eyes and respiratory system against dust and other foreign particles.

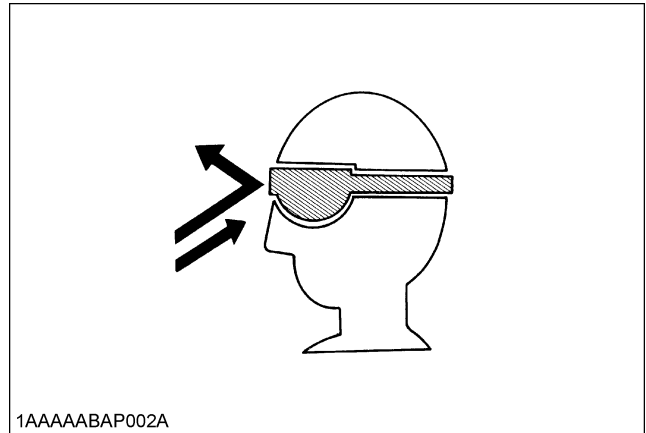

14. Securely support excavator with stands or suitable blocking before working underneath. For your safety, do not work under any hydraulically supported devices. They can settle, suddenly leak down, or be accidentally lowered.
15. Do not dismantle the spring of the track tensioner. If dismantling is necessary, contact your KUBOTA dealer where the machine was purchased, or competent service shop. The assembly must be done according to the work shop manual of KUBOTA (W.S.M.) for the product involved.
16. When lifting the machine itself with an attachment, place a safety block or safety post to prevent the machine from turning over. Keep the lock lever for attachment control in the "LOCK" position.

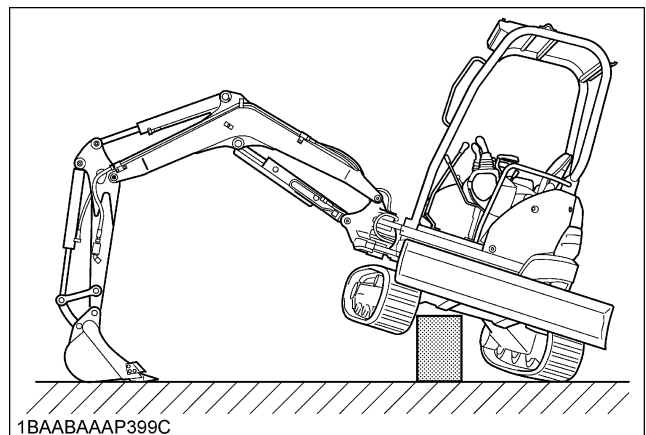

17. KUBOTA uses no parts which are lined with asbestos. Do not use these kind of parts even if they are available and can be installed.

6. DANGER, WARNING AND CAUTION LABELS

(1) Code No. RC418-5728-4



CAUTION

TO AVOID PERSONAL INJURY:

1. Read and understand operator's manual before attempting to start or operate the excavator.
2. Before starting engine, make sure all control levers are in neutral and the operating area is clear of all bystanders.
3. Never allow passengers on any part of the excavator while operating.
4. Know your work area before starting operation.
 - Check underground lines and cables.
 - Stay off slopes too steep for safe operation.
 - Check overhead clearance with electric wires.
 - Check for hidden holes, obstacles or drop-offs and overhangs.
5. Make sure all shields are in place and securely fastened.
6. Before dismounting from the machine, lower all attachment to the ground, stop the engine and remove the key.
7. Damaged ROPS must be replaced, not repaired or revised.

IMPORTANT Never use boom, dipper, or bucket to hammer or beat sideways. Excavator is not intended for these usages.

1BAAAAQAP0780

(2) Code No. RC418-5727-4

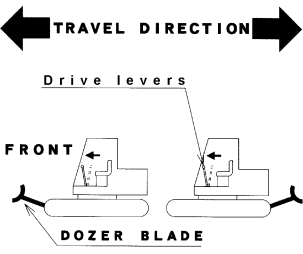

TRAVEL DIRECTION

Drive levers

FRONT

DOZER BLADE



WARNING

TO AVOID PERSONAL INJURY OR DEATH:
Before moving the excavator, KNOW THE LOCATION OF THE DOZER BLADE. The excavator will travel in the direction of the dozer blade when drive levers are moved away from the operator.



DO NOT OPERATE WITHOUT ROPS. YOU COULD BE CRUSHED.

USE SEAT BELT

1BAAAAQAP0790

(3) Code No. RC418-5733-2



DANGER



TO AVOID SERIOUS INJURY OR DEATH:
Check overhead clearance with electric wires.

1BAAAAQAP0800

(4) Code No. RB548-5754-3



WARNING

TO AVOID PERSONAL INJURY OR DEATH:

- Do not move raised load over people.
- It is forbidden to lift loads greater than those values mentioned in the lifting capacity tables.
- The values mentioned in the table are valid only on even, hard grounds. When lifting on soft ground, the machine can tilt over due to the fact that the load is concentrated only on one side of the machine.
- The table values are calculated at the end of the arm without the bucket. In order to find the allowable loads for machines with bucket, the bucket weight must be subtracted from the values in the table.

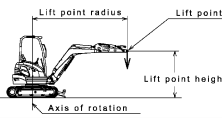

Lift point radius

Lift point

Lift point height

Axis of rotation

1. The lifting capacities are based on ISO 10567 and do not exceed 75% of the static tilt load of the machine or 87% of the hydraulic lifting capacity of the machine.
2. The strokes are as follows.
 - 1) The load point corresponds to the front ball part of the arm.
 - 2) The machine positions are (i) over-front (Blade down), (ii) over-front (Blade up), and (iii) over-side.
 - 3) The operating cylinder is the boom cylinder.
3. The bucket of the excavator, the hook, the sling and other lifting accessories are taken into consideration for the loads.



LIFT POINT HEIGHT (m)	LIFTING CAPACITY OVER-FRONT BLADE DOWN Unit: t (kN) (kg)				LIFTING CAPACITY OVER-FRONT BLADE UP Unit: t (kN) (kg)				LIFTING CAPACITY OVER-SIDE Unit: t (kN) (kg)			
	LIFT POINT RADIUS (m)				LIFT POINT RADIUS (m)				LIFT POINT RADIUS (m)			
	1.0	1.5	2.5	3.5	1.0	1.5	2.5	3.5	1.0	1.5	2.5	3.5
2.5				3.7 (380)				3.4 (340)				2.9 (290)
2.0				4.1 (420)				3.3 (340)				2.9 (290)
1.0				6.4 (650)				5.4 (550)				4.5 (460)
0				7.7 (790)				5.2 (530)				4.2 (430)
-1.0	11.4 (1160)	14.4 (1470)	7.0 (720)	3.9 (400)	11.4 (1160)	12.9 (1310)	5.1 (520)	3.2 (320)	11.4 (1160)	9.1 (930)	4.2 (430)	2.6 (270)
-2.0				6.2 (630)				6.2 (630)				6.2 (630)

Machine with ROPS canopy and rubber crawler, without bucket

1BAAEUAP023E

(5) Code No. RD809-5738-2



WARNING

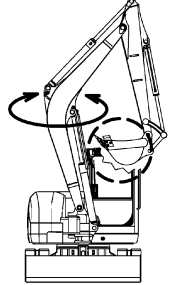

ATTACHMENT IMPACT HAZARD
KEEP ATTACHMENT AWAY FROM CAB AND MACHINE. FAILURE TO DO SO MAY RESULT IN SEVERE INJURIES OR DEATH OR DAMAGE TO THE BOOM/CYLINDER, HYDRAULIC HOSES OR THE CAB.

1BAAAARAP1000

1BAAAARAP042D

(1) Code No. RD118-5763-1

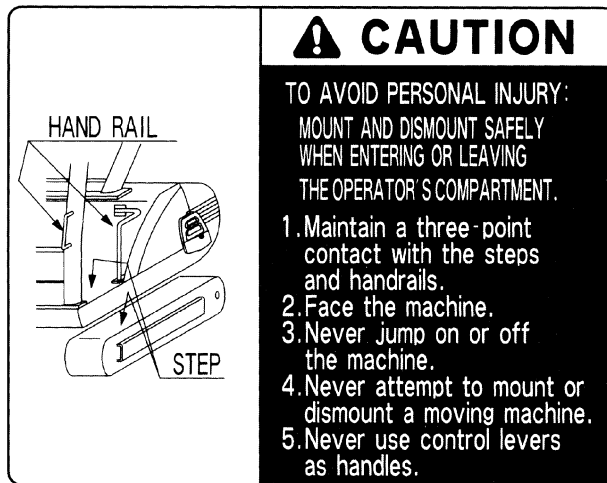

1BAAGAAAP0160

(2) Code No. RC418-5753-1

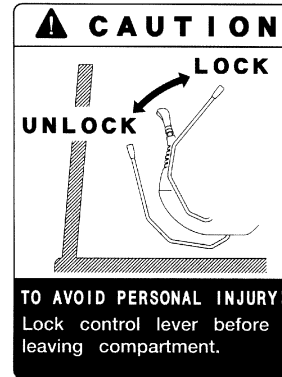

1BAAAARAP0450

(3) Code No. RB548-5732-1

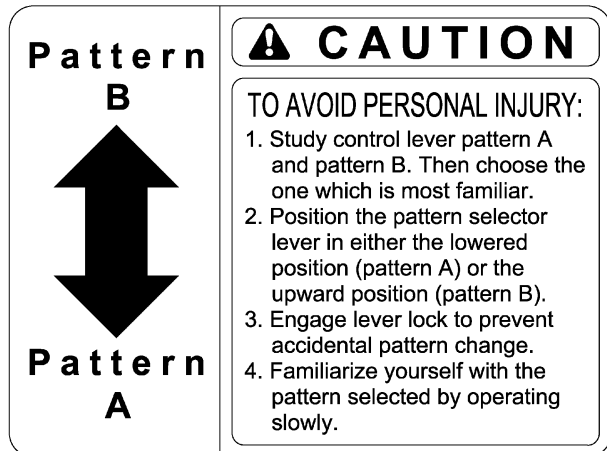

1BAAEUAP020E

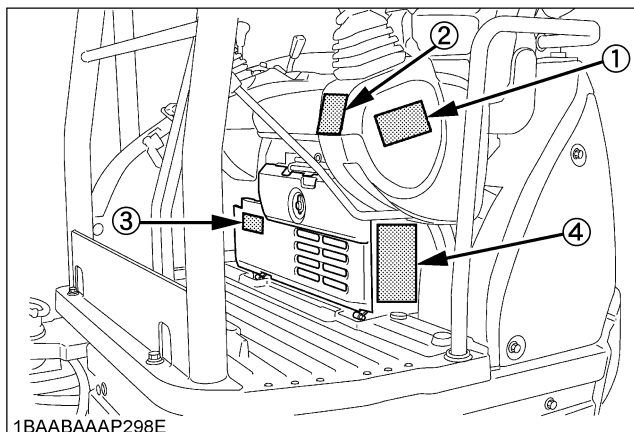

(4) Code No. RC348-5728-1

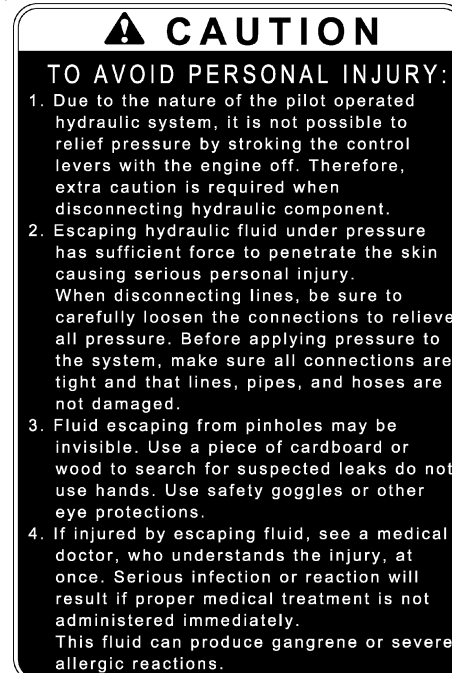

1BAAEUAP021E

(1) Code No. RC108-5718-1

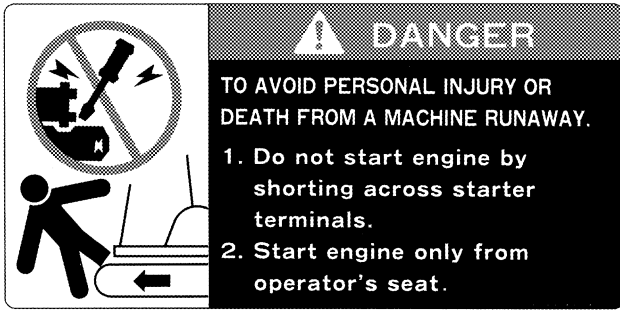

1BAAAQAP0910

(2) Code No. RC108-5796-1
[Both sides]

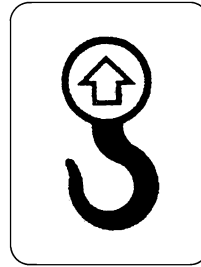

1BAAAQAP0940

(3) Code No. 68328-5735-1 [Both sides]

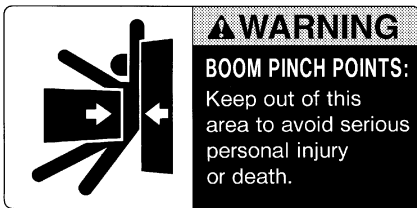

1BAAAQAP0930

(4) Code No. RD148-5736-1
Diesel fuel only No fire

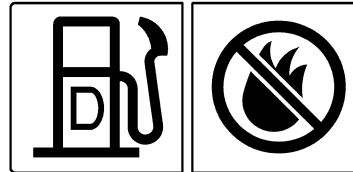

LOW SULFUR FUEL OR
ULTRA LOW SULFUR
FUEL ONLY

1BAAGAAP1000

(5) Code No. RD517-5795-1 [Both sides]

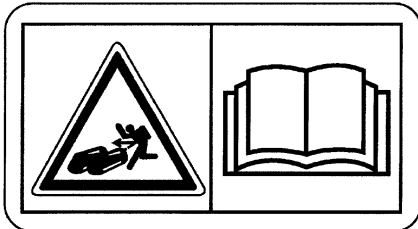

1BAABAMAP0010

(6) Code No. RB419-5796-1
[Both sides]

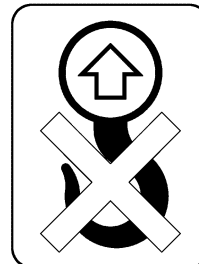

1BAABAUAP2720

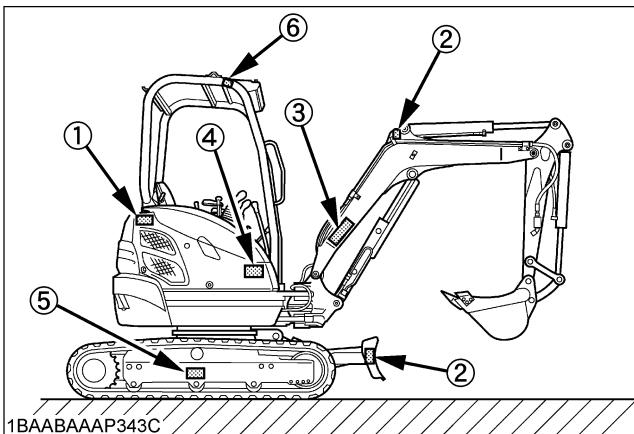

1BAABAAAP343C

(1) Code No. 6C040-5559-1

DANGER EXPLOSIVE GASES
 Cigarettes, flames or sparks could cause battery to explode. Always shield eyes and face from battery. Do not charge or use booster cables or adjust post connections without proper instruction and training.
KEEP VENT CAPS TIGHT AND LEVEL
POISON CAUSES SEVERE BURNS
 Contains sulfuric acid. Avoid contact with skin, eyes or clothing. In event of accident flush with water and call a physician immediately.
KEEP OUT OF REACH OF CHILDREN

1BAAAQAP0960

(2) Code No. RC108-5754-1



1BAAAQAP0890

(3) Code No. TA040-4958-1
 Do not touch hot parts such as exhaust etc.



1BAAAQAP0860

(4) Code No. RC418-5737-2
 Keep away from fan and fan belt.



1BAAAQAP0880

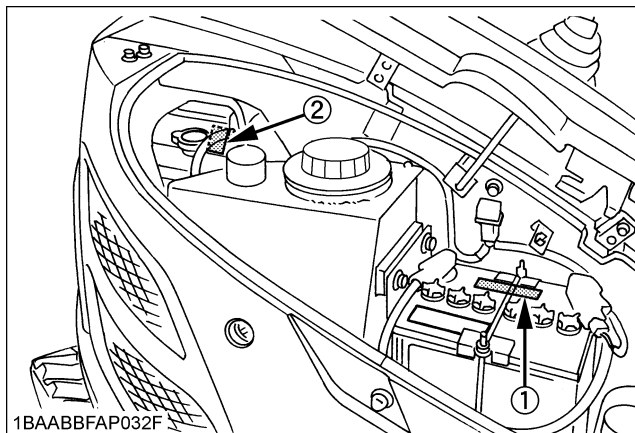

1BAABBFAP032F

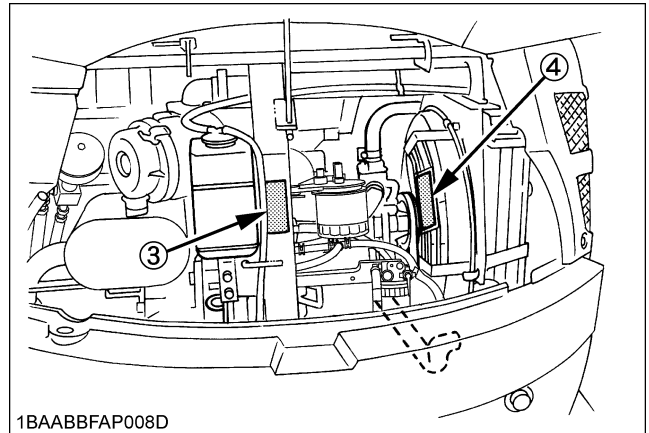

1BAABBFAP008D

- (1) Code No. RC418-5725-1 [Both sides]
Do not allow any persons within the working range.

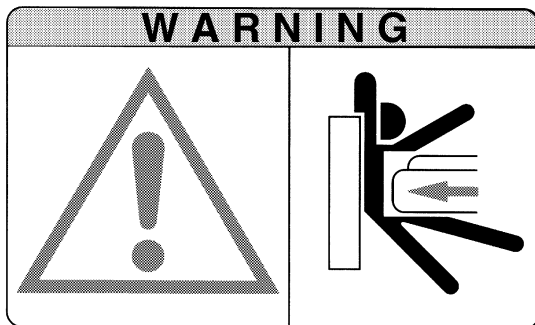

1BAAAAQAP0900

- (2) Code No. RD118-5737-1



1BAAAARAP062E

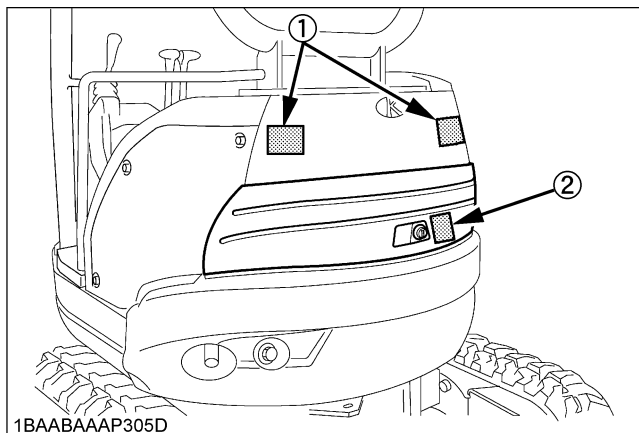

1BAABAAAP305D

7. CARE OF DANGER, WARNING AND CAUTION LABELS

1. Keep danger, warning and caution labels, clean and free from obstructing material.
2. Clean danger, warning and caution labels with soap and water, dry with a soft cloth.
3. Replace damaged or missing danger, warning and caution labels with new labels from your KUBOTA dealer.
4. If a component with danger, warning and caution label(s) affixed is replaced with new part, make sure new label(s) is (are) attached in the same location(s) as the replaced component.
5. Mount new danger, warning and caution labels by applying on a clean dry surface and pressing any bubbles to outside edge.

DEALER SERVICE

Your KUBOTA dealer is always ready to help so that your excavator offers the best performance. After having carefully read this manual, you will realize that much of the routine maintenance can be done by yourself. Your KUBOTA dealer is responsible for servicing and the delivery of spare parts. When ordering spare parts from your KUBOTA dealer, always mention the serial number of the excavator and the engine.

Note these numbers right away in the supplied lines.

	Model	Serial No.
Excavator		
Engine		
Dealer's name (To be filled in through the owner)		

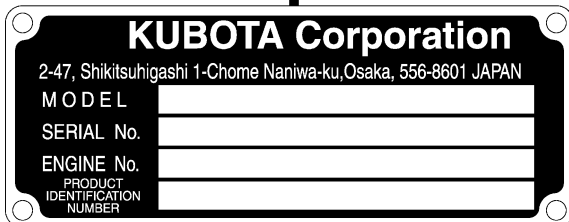
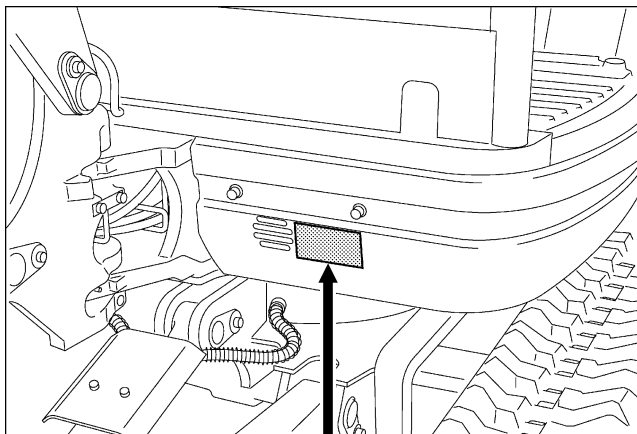

1BAAABSAP099B

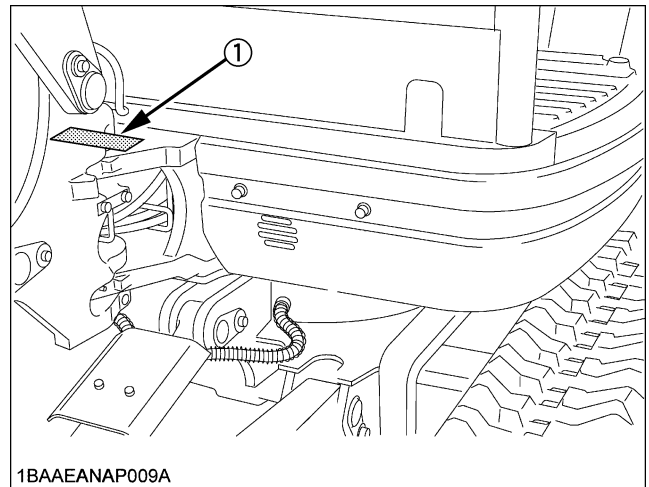

1BAAEANAP009A

(1) Serial No.

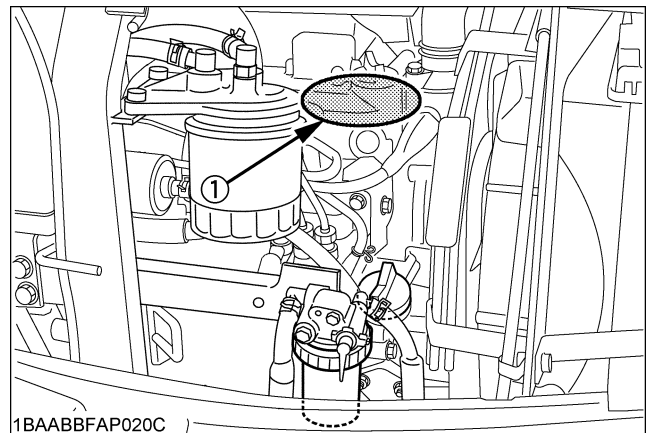

1BAABBFAP020C

(1) Engine serial No.

TECHNICAL DATA

		KUBOTA EXCAVATOR		
Model name		U25		
Type		Canopy		
Operating weight (including operator's)		kg	2550	
Engine	Type		Water cooled 3 cylinder diesel engine	
	Model name		KUBOTA D1105-E3-BH-14	
	Total displacement	cc	1123	
	Engine power SAE gross	kW(Hp)	15.5 (21)	
	Rated speed	rpm	2400	
Performance	Unit swing speed	rpm	9.8	
	Travel speed	Fast	km/h	4.5
		Slow	km/h	2.5
	Ground pressure (With operator)	kPa (kgf/cm ²)	22.9 (0.23)	
	Climbing angle	%(deg)	*36 (20)	
Angle in case of crossing slope	%(deg)	*27 (15)		
Dozer	Width X Height	mm	1500 x 300	
Boom swing angle	Left	rad(deg)	1.31 (75)	
	Right	rad(deg)	0.96 (55)	
Pressure connection for attachments	Max. displacement (Theoretical)	L/ min	48.0	
	Max. pressure	Mpa (kgf/cm ²)	21.6 (220)	
Fuel tank capacity		L	28	

NOTE :

- Above dimensions are based on the machine with rubber tracks and JPN bucket.
JPN = made in Japan
- Specifications subject to change without notice.
- * With unloaded digging bucket.
- * Firm compacted soil.
- * Operators must exercise extra caution and follow instructions in the operator's manual.
- * Worse condition or heavier attachment to the above will decrease climbing angle.

DESCRIPTION OF MACHINE PARTS

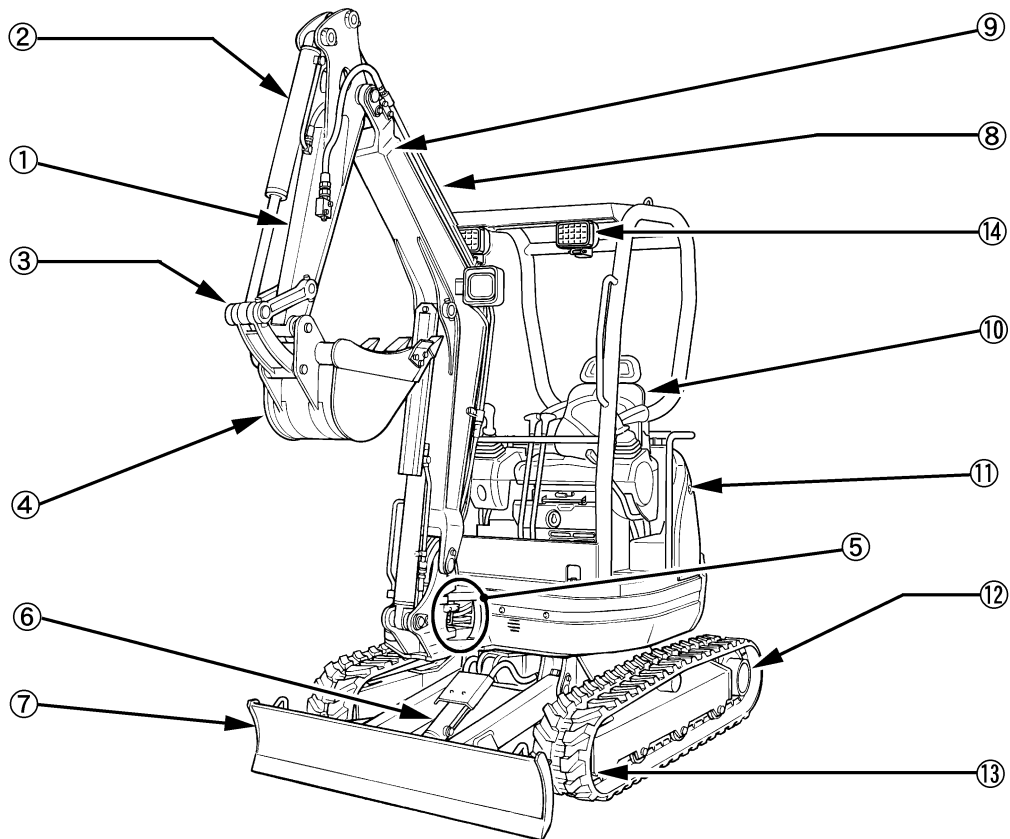

1BAAEYAP003A

DEPICTED CONTENTS

- (1) Arm
- (2) Bucket cylinder
- (3) Bucket link
- (4) Bucket
- (5) Swing bracket
- (6) Dozer cylinder
- (7) Dozer
- (8) Arm cylinder
- (9) Boom
- (10) Operator's seat
- (11) Engine bonnet
- (12) Drive sprocket
- (13) Front idler
- (14) Working light

INSTRUMENT PANEL AND CONTROL ELEMENTS

■ Instrument Panel, Switch

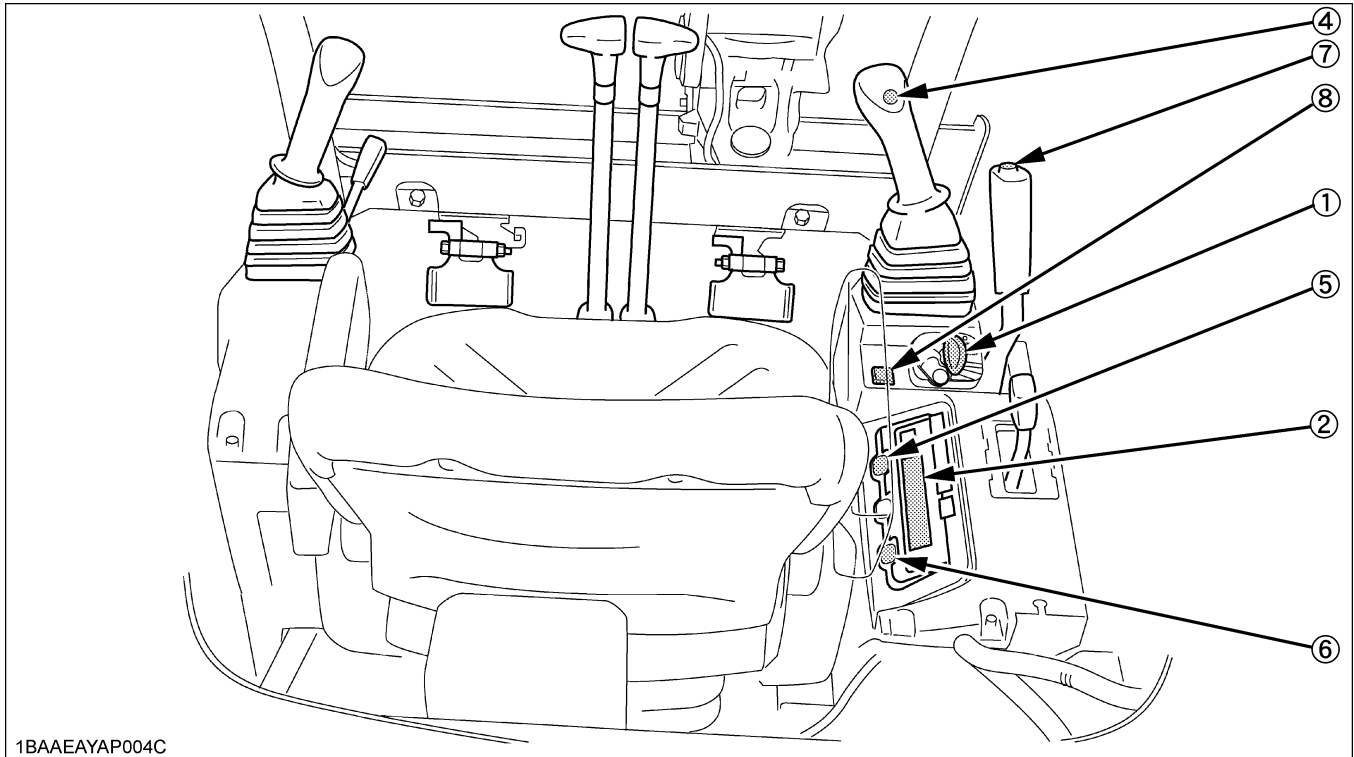

1BAAEAYAP004C

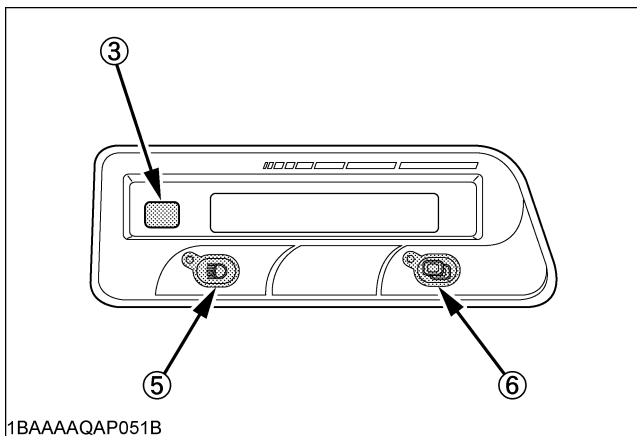

1BAAAQAP051B

DEPICTED CONTENTS

- (1) Starter switch
- (2) LCD display
- (3) Warning lamp
- (4) Horn switch
- (5) Working light switch
- (6) Display selector switch
- (7) Travel speed switch
- (8) Speed indicator light

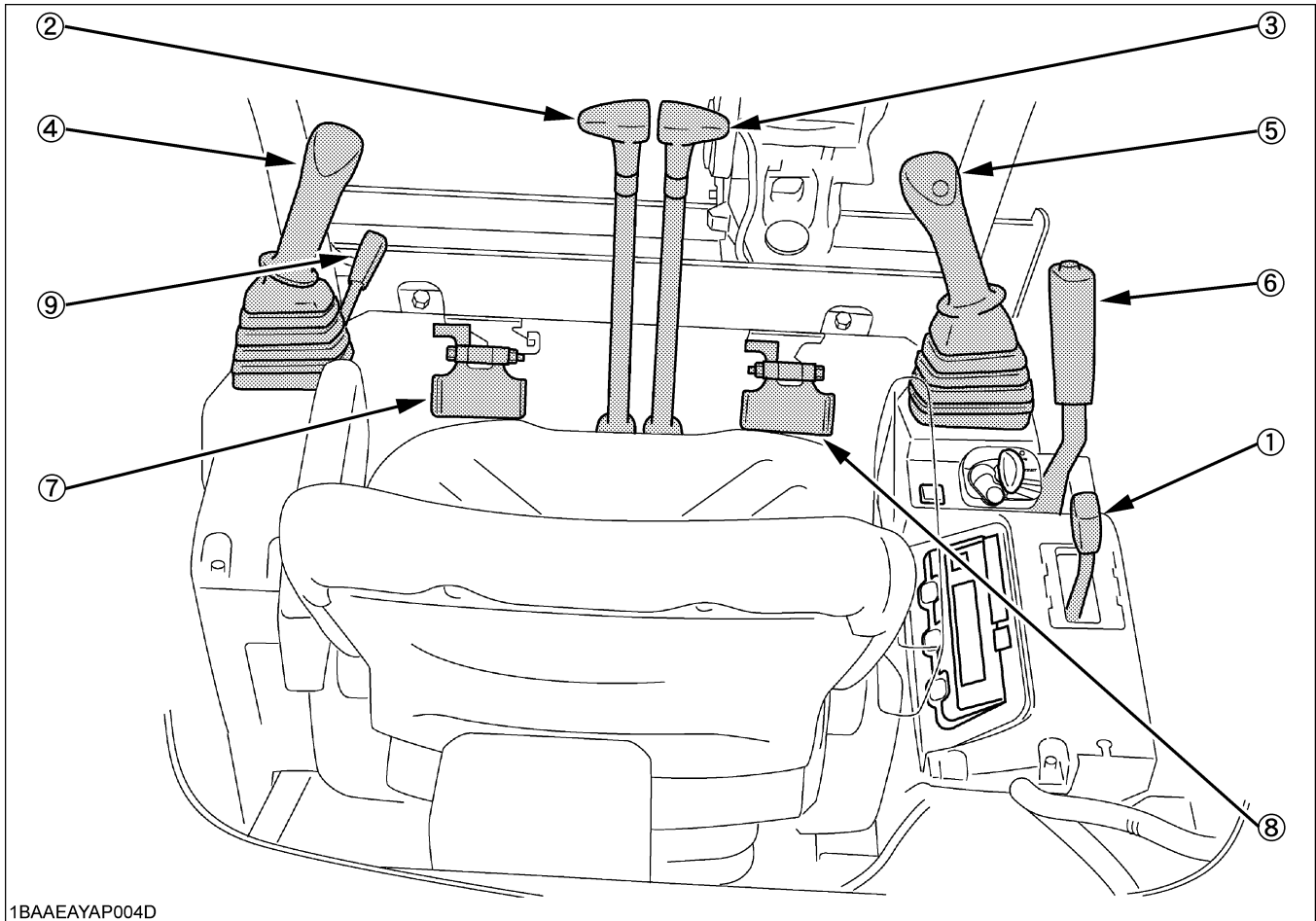

1BAAEAYAP004D

DEPICTED CONTENTS

- (1) Throttle lever
- (2) Drive lever (left)
- (3) Drive lever (right)
- (4) Control lever for front attachments (left)
- (5) Control lever for front attachments (right)
- (6) Dozer control lever
- (7) Service port pedal
- (8) Boom swing pedal
- (9) Lock lever*

IMPORTANT :

* When the lock lever pulled up prevents inadvertent machine movement.

CHECKS BEFORE START

DAILY CHECKS

In order to avoid damage, it is important to check the condition of the excavator before starting.



CAUTION

To avoid personal injury:

- Do maintenance work on the excavator only on even ground with the engine off and the stop lever in the "Lock" position.

Checks

Go around the excavator and check for visual damage and wear.

Check coolant level. (See regular checkpoints in the chapter on maintenance.)

Check fuel level.

Check engine oil level.

Check hydraulic fluid level.

Check air filter for clogging.

Check all control lamps, indicators, revolution counter and hour meter.

Check the light system.

Check the condition of the safety and warning labels. (See "DANGER, WARNING AND CAUTION LABELS" in "SAFE OPERATION" .)

SLIDING THE SEAT



CAUTION

To avoid personal injury:

- Lock the lever for attachment control when sliding the seat.

To slide the seat forward, pull the seat sliding lock lever and tilt the seat forward.

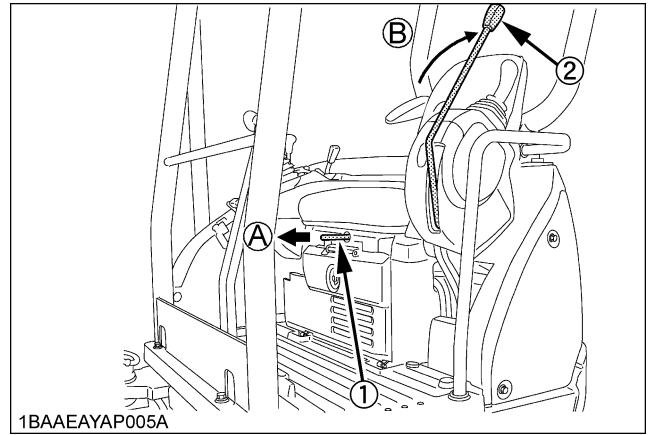

(1) Seat sliding lock lever

(A) "Sliding forward"

(2) Lock lever for attachment control

(B) "Lock"

OPENING AND CLOSING OF PARTS

■ Opening / Closing of the Engine Bonnet



CAUTION

To avoid personal injury:

- Do not touch the exhaust muffler or the exhaust pipe; serious burns can occur.

Insert the key into the key hole and turn it clockwise to unlock, and lift up the bonnet until the stay locks automatically.

For closing, lift up the bonnet and release the stay.

Push down the bonnet until it locks automatically.

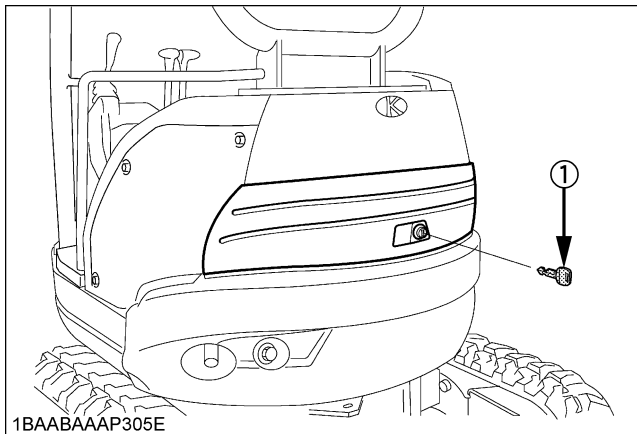

(1) Key

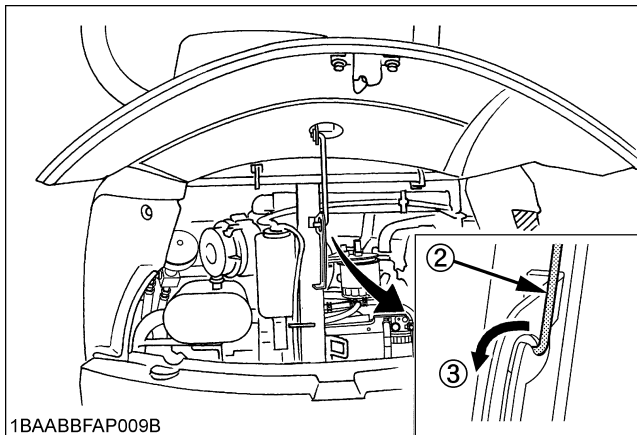

(2) Stay
(3) Unlock

■ Opening and Closing of the Fuel Tank Cover

To open the tank cover, first insert the key into the key slot and turn it counterclockwise to unlock, then open the tank cover upward.

For closing, return the tank cover to original position and turn the key clockwise to lock, then remove the key.

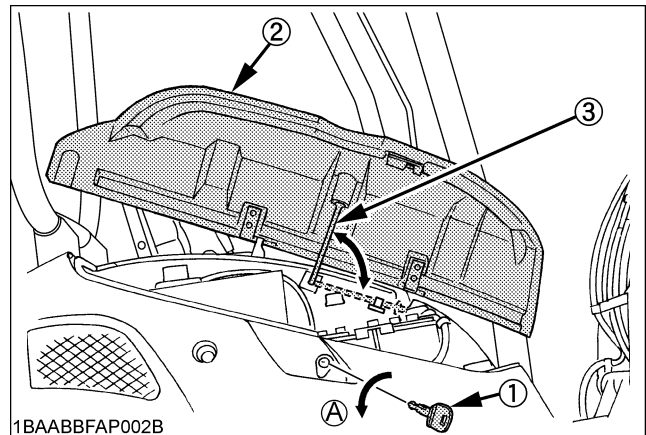

(1) Key
(2) Tank cover
(3) Stay

(A) Unlock

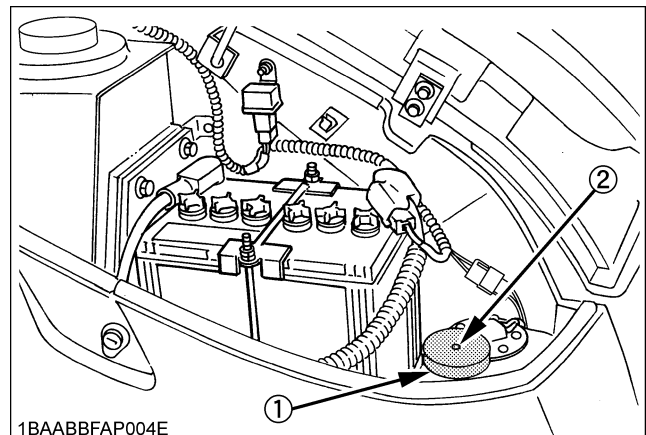

(1) Fuel tank cap
(2) Air vent

■ Keeping the Tools

Pull the seat sliding lock lever and slide the seat forward.

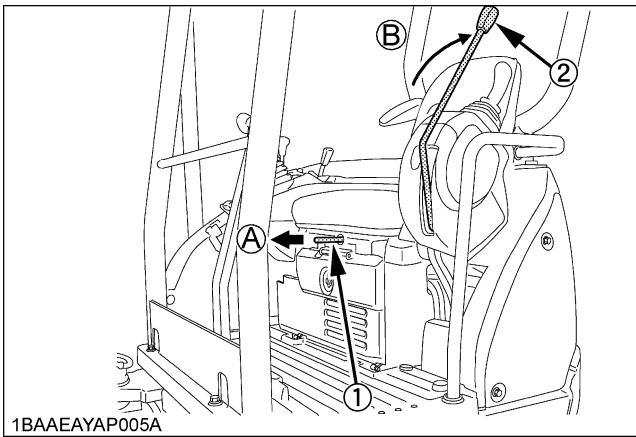

(1) Seat sliding lock lever (A) "Sliding forward"
 (2) Lock lever for attachment control (B) "Lock"

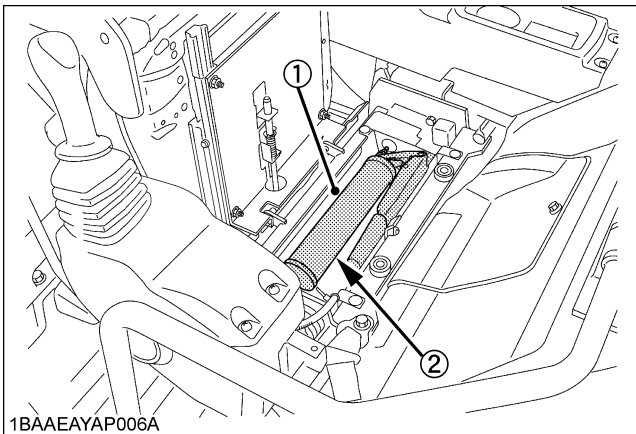

(1) Tool Box
 (2) Grease gun

■ Operator's Manual Storage

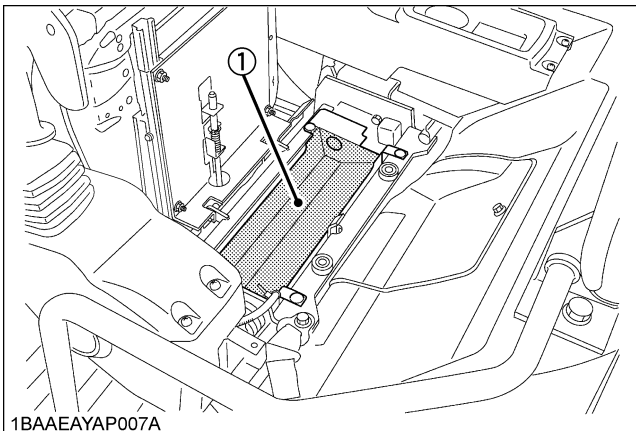

(1) Operator's manual

HANDLING THE SAFETY DEVICES

■ Control Lever Lock



CAUTION

- When the excavator is not used or left unattended, be sure to place the lock lever in position "Lock".

The attachment control lever lock is located on the left side.

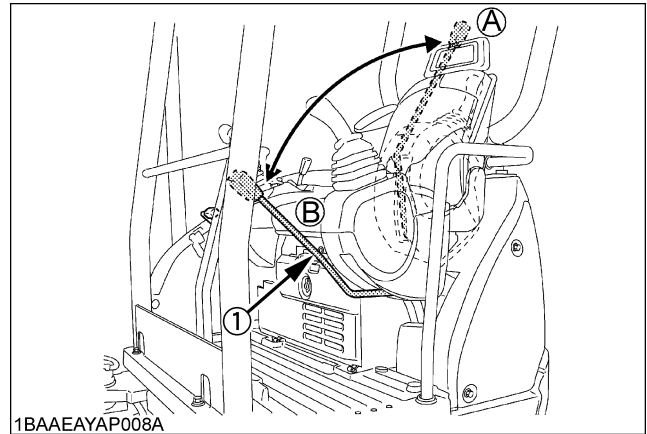

(1) Lock lever for attachment control (A) "Lock"
 (B) "Unlock"

**■ Roll-Over Protective Structures (ROPS) /
Falling-Objective Protective Structures
(FOPS)**

For your safety, ROPS / FOPS with a seat belt is installed with your machine. A ROPS / FOPS label is fastened to the ROPS / FOPS. This label shows the serial No. of ROPS / FOPS, gross weight, approval and regulation No. and model No. of the machine.

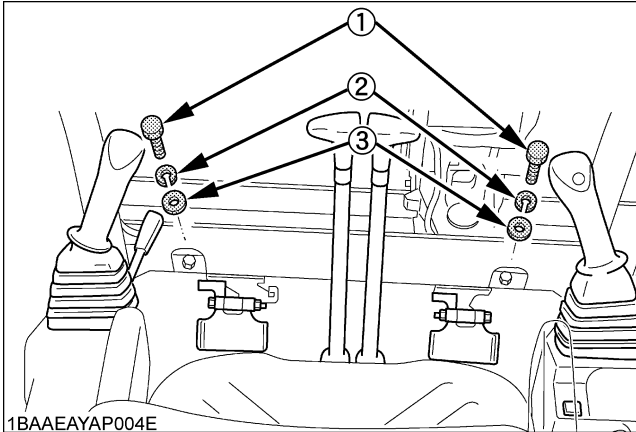

1BAAEAYAP004E

- (1) Bolt
- (2) Spring washer
- (3) Plain washer

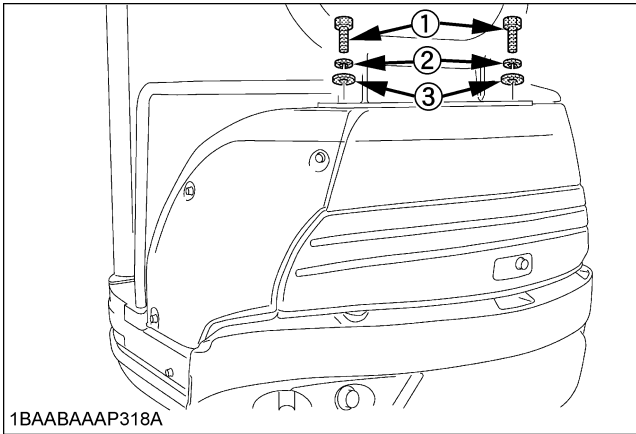

1BAABAAAP318A

- (1) Bolt
- (2) Spring washer
- (3) Plain washer

ROPS MEETS REQUIREMENTS OF
 OSHA 1926 • 1001/ISO 3471 1994/SAE J1040 MAY94
 FOPS (LEVEL 1) MEETS REQUIREMENTS OF
 OSHA 1926 • 1003/ISO 3449 1992/SAE J/ISO 3449

ROPS • FOPS (LEVEL 1) MODEL: KUBOTA	MACHINE MODEL: KUBOTA
ROPS • FOPS (LEVEL 1) SERIAL No.	MAX. GROSS MACHINE MASS
ROPS PART	2-47, SHIKITSUHIGASHI 1-CHOME NANIWA-KU, OSAKA 556-8601, JAPAN

KUBOTA Corporation
 OSAKA, JAPAN

		ROPS MODEL No.	ROPS PARTS No.	MAX. GROSS MACHINE MASS
U25	CANOPY	RFP 2820	RB419-4531△	2820 kg



WARNING

To avoid personal injury or death:

- Do not modify a ROPS / FOPS in any way. Welding, grinding, bending, drilling or cutting any portion of the ROPS / FOPS may weaken the structure. Do not repair a damaged ROPS / FOPS. A damaged ROPS / FOPS structure must be replaced, not repaired or revised. If any structural member of the ROPS / FOPS is damaged, replace the entire structure at your local KUBOTA dealer. Check the seat belt daily and replace it if damaged or frayed.
- Do not remove the ROPS / FOPS except for service. Install the ROPS / FOPS correctly before you operate the machine again.

	QTY.	Grade	Tightening Torque
Bolt M14	2	9T	124 to 147 N-m (12.6 to 15.0 kgf-m)
Bolt M16	2	9T	196 to 226 N-m (20.0 to 23.0 kgf-m)
Nut M14	4	6T	108 to 126 N-m (11.0 to 12.8 kgf-m)
Nut M16	4	6T	167 to 191 N-m (17.0 to 19.5 kgf-m)

- Do not install any attachments that will cause the total gross weight of the machine to exceed the weight shown in the "FOR MAXIMUM GROSS MACHINE WEIGHT" space on the ROPS / FOPS label.

OPERATION OF THE ENGINE



CAUTION

To avoid personal injury:

- Read "SAFE OPERATION" at the beginning of this operator's manual.
- Obey the danger, warning and caution labels on the excavator.
- To avoid the danger of exhaust fume poisoning, do not operate the machine in a closed building without proper ventilation.
- Always start the engine from the operator's seat. Do not start the engine while standing next to the excavator. Before starting the engine, sound the horn to get the attention of persons standing nearby.

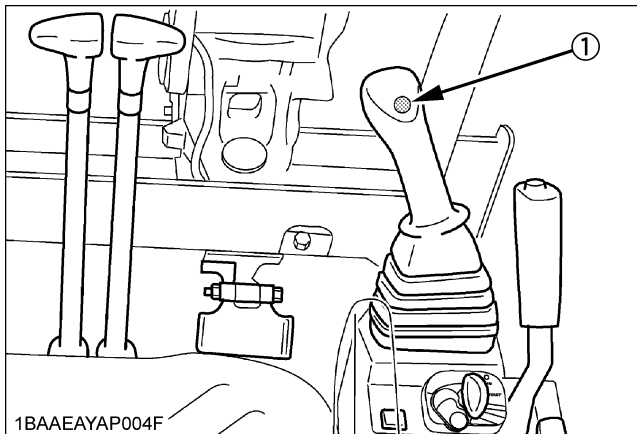

(1) Horn switch

IMPORTANT :

- Do not use starting fluid or ether.
- In order not to overload the battery and starter, avoid start-ups of more than 10 sec.
- When engine does not start in 10 sec., please wait 20 sec. or more, before attempting to restart.

STARTING THE ENGINE



CAUTION

To avoid personal injury:

- The operator should not depend solely on the warning lamps, but should always conduct the routine checks (see "MAINTENANCE").

Start the engine in the following manner:

1. Before starting the engine, make sure that all control levers are in the neutral positions.

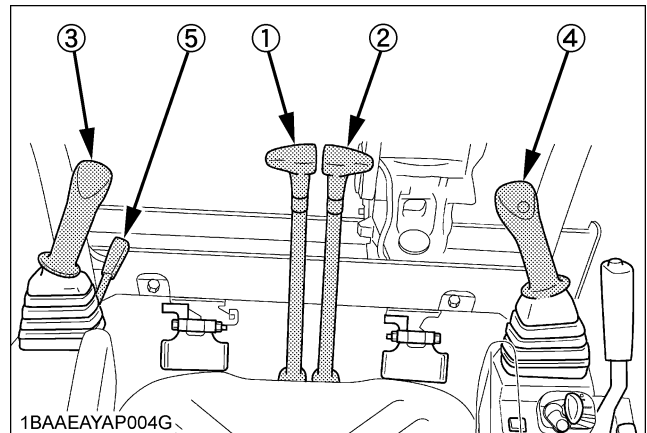

- (1) Drive lever (left)
- (2) Drive lever (right)
- (3) Attachment control lever (left)
- (4) Attachment control lever (right)
- (5) Lock lever

2. Pull the lock levers all the way back. (lock position)
 - Put the throttle lever towards
3. Insert the key into the starter switch and turn it to the position "Run". The glow lamp indicator will light up while the engine is preheated and will go out automatically after preheating is finished.

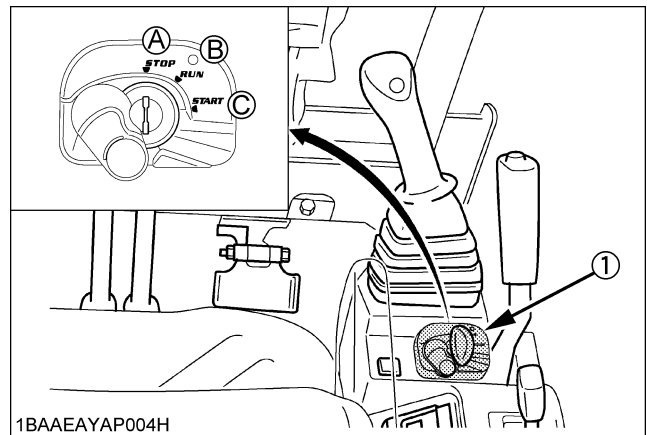

- (1) Starter switch
- (A) "STOP"
- (B) "RUN"
- (C) "START"

4. Turn the key to the position "START" and release after the engine has started.
5. Check if oil lamp and charge lamp have gone out. Should a warning lamp still be lit up, stop the engine then remove the key and check for the cause.

NOTE :

- When the lock levers are in "UNLOCK" position, the engine does not start.

■ Display Selector Switch

Press the display selector switch. The LCD meter display will change from one indication mode to the other. Change the two-mode display according to your jobs.

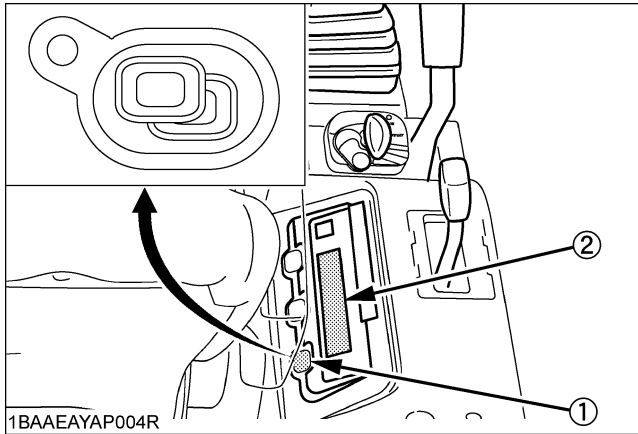

(1) Display selector switch
(2) LCD display

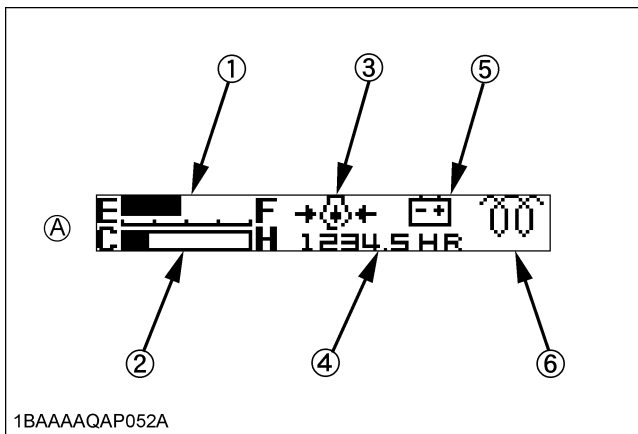

(1) Fuel gauge (A) "INDICATION MODE 1"
(2) Water temperature gauge
(3) Oil lamp
(4) Hour meter
(5) Charge lamp
(6) Glow lamp

NOTE :

- With the starter key at the "STOP" position, press the electronic meter's display selector switch or the working light switch, and the LCD display shows the hour meter, fuel gauge and water temperature gauge for 10 seconds.



■ Charge Lamp

This warning lamp lights up if the charging system fails the engine running. When the starter switch is turned "RUN" with the engine off, the lamp lights up, and when the engine gets started, the lamp goes out. If the lamp stays on with the engine running, stop the engine and check the fan belt.

NOTE :

- If there is disconnection or failure in the charging system when the key is turned to "RUN", the following □ symbol will appear.



■ Oil Lamp

The engine oil pressure warning lamp lights up due to failure of the lubricating system with the engine running. When the starter switch is turned "RUN" with the engine off, this lamp lights up, and when the engine starts, the lamp goes out. If the lamp stays on with the engine running, stop the engine and check the engine oil level.

NOTE :

- If there is disconnection, failure or breakdown in the lubricating system when the key is turned to "RUN", the following □ symbol will appear.



■ Glow Lamp

With the starter key at the "RUN" position, the engine's preheat status is indicated.

NOTE :

- When the starter switch is turned to the "RUN" position, the engine will be preheated for a given period of time and the lamp will turn on.
- The above indication appears momentarily when the engine is started, but it does not mean any trouble. (This is because the oil charge sensor output becomes unstable when the engine is started.)
- The □ symbol appears momentarily as the engine starts. This is not an error.

■ LCD Display for Normal Operation

◆ Fuel gauge

CAUTION

To avoid personal injury:

- Before adding fuel, be sure to stop the engine.
- Be sure to keep open flame away from the machine. Otherwise a fire may be caused.

With the starter key at the "RUN" position, the fuel remaining in the fuel tank is indicated in the block.

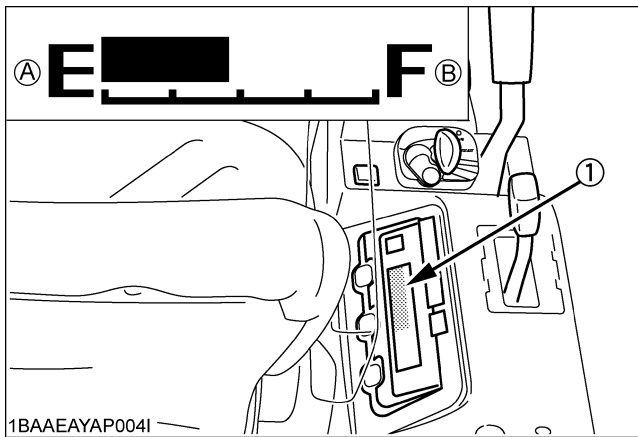

(1) Fuel gauge

(A) "Empty"
(B) "Full"

NOTE :

- If the fuel gauge indicator is near the "E" or the "FUEL" message appears, add fuel as soon as possible. If the indicator is near "E" and the machine runs on a slope, the engine may run out of fuel and get interrupted.

◆ Fuel supply

CAUTION

To avoid personal injury:

- If the fuel is poured too fast, the buzzer may not sound according to the fueling process.
- The moment when the fuel tank is nearly full, the buzzer starts beeping.
- Look into the fuel tank when pouring the fuel. Listen to the buzzer sound for a rough estimate of the fill-up progress.

The following functions are helpful when adding the fuel. The fueling process can be monitored by a buzzer sound.

Procedure

1. Press the work light switch or the display selector switch on the meter with the key OFF. (Keep the key at OFF.)



2. The message shown above appears.
3. Add fuel.
4. The buzzer sound interval changes according to the amount fuel added. As the fuel amount becomes close to full, the buzzer sound changes to continuous beeping.

◆ Water Temperature Gauge

CAUTION

To avoid personal injury:

- Do not open the radiator cap during or just after operation. Hot water may gush out and scald you. Wait for the water to cool down before opening the cap.

With the starter key at the "RUN" position, the cooling water temperature is indicated. If the water temperature indicator is near "H", take the steps below.

1. Discontinue the job.
2. Reduce engine rpm's to idle and keep it at idle for 5 minutes.
3. Stop the engine and check the following points (1)-(3).
 - (1) Low coolant level or leak
 - (2) Fan belt tension
 - (3) Mud or dust deposits on radiator

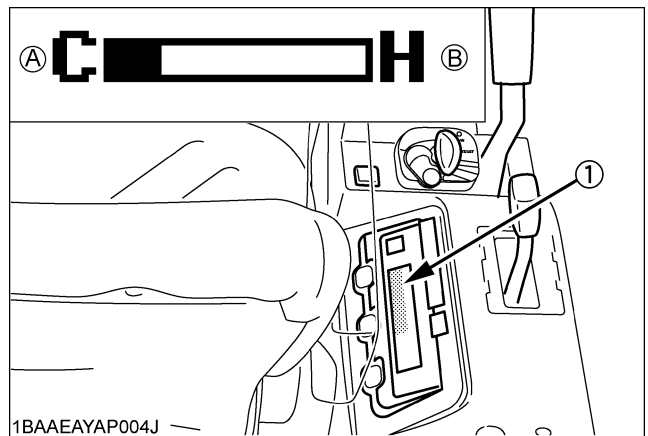

(1) Water temperature gauge

(A) "WATER TEMP LOW"
(B) "WATER TEMP HIGH"

◆ Hour-meter

Indicates the total operating hours of the machine.

How the indicator works

- The meter advances one hour after an hour of operation regardless of the engine rpm.



◆ Engine tachometer

Indicates the current rpm of the engine.



NOTE :

- The LCD display may be illegible when viewed from a certain angle. This is not a display failure.

■ LCD Display for Warning

◆ Remaining fuel warning

When the fuel level is very low, the ▲ lamp (yellow) starts flashing and the following message appears in the display.

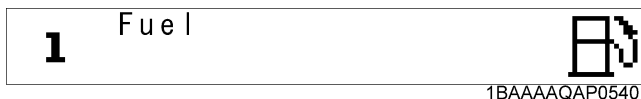

◆ Battery charge warning

If the charging system fails, the ▲ lamp (red) starts flashing and the following message appears in the display.

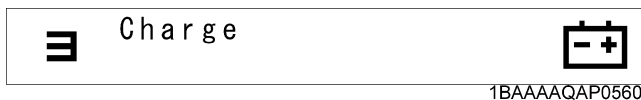

◆ Engine oil pressure low warning

When the engine oil pressure drops too low, the ▲ lamp (red) starts flashing and the following message appears in the display.

Immediately stop the engine and check the engine oil level.

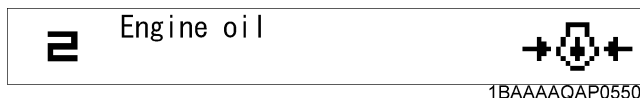

■ Warning Lamp

The warning lamp is used to indicate broken wire, short-circuit, fuel shortage and other problems.

The warning lamp starts flashing in red if any trouble occurs. If the system gets in warning signal, the warning lamp starts flashing in yellow.

IMPORTANT :

- Do not just look at the meter, but also carry out the inspection and correction accordingly.

NOTE :

- Warnings and errors are displayed and an alarm buzzer beeps.
- Let your KUBOTA dealer inform you of details concerning care and maintenance.

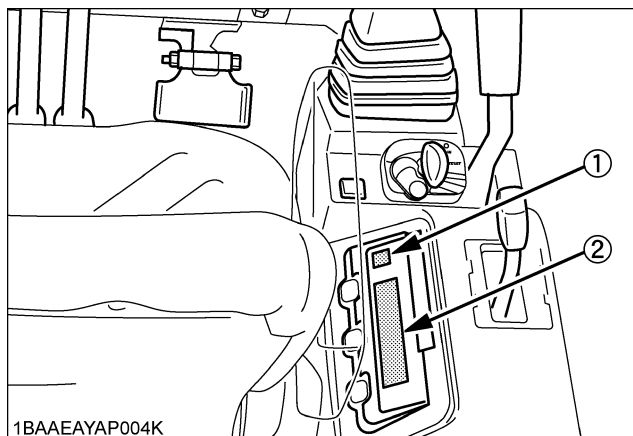

- (1) Warning lamp (red, yellow)
- (2) LCD display

■ Checkpoints after Starting the Engine

After starting the engine, but before starting operation, check the following points:

1. Put the throttle lever in position "LOW" and let the engine idle for approx. five minutes. This allows the engine lubricant to warm up and penetrate every part of the engine.

Note:

- This idling is usually called "Warm-up".
2. Once the engine has warmed up, check:
 - the warning lamp "Engine oil pressure" has gone out.
 - the warning lamp "Battery charge" goes out when engine speed is increased.
 - the color of the exhaust is normal and no abnormal noises or vibrations are heard or felt.
 - no fluid is leaking from pipes or hoses.

◆ Should any following conditions occur, stop the engine immediately.

- The engine rpm's increases or decreases suddenly.
- Sudden abnormal noises are heard.
- Exhaust is black.
- Warning lamp for engine oil lights up during operation.

IMPORTANT :

- In these cases, the excavator must be checked and serviced by your local the KUBOTA dealer.

STARTING THE ENGINE UNDER COLD CONDITIONS



CAUTION

To avoid personal injury:

- Make sure that the lock lever is in the lock position during warm up.

Start the engine in the following manner;

1. Pull the lock levers all the way back (lock position).
2. Turn the starter switch to the position "RUN" (glow position) and keep until the indicator lamp has gone out.
3. Move the starter switch to the position "START"; to crank and start engine.
4. Release the starter switch after the engine has started; it will automatically return to the position "RUN".

IMPORTANT :

- Let the engine warm up after start-up for approx. 10 minutes under no load conditions. If the hydraulic fluid temperature is too low, the operations will be affected. Do not operate the excavator under full load before the engine has warmed up enough.

STOPPING THE ENGINE



WARNING

To avoid personal injury or death:

- Do not keep the bucket or dozer in the lifted position, as a person, could accidentally touch the levers and cause serious accidents.

1. After slowing the engine to idle, turn the key to "STOP".
2. Remove the key.

■ Engine Stop Lever



CAUTION

To avoid personal injury:

- Keep hands away from rotating parts.

The engine stops when the key is turned off. If the engine does not stop, open the engine hood and push the stop lever back and hold it until the engine stops.

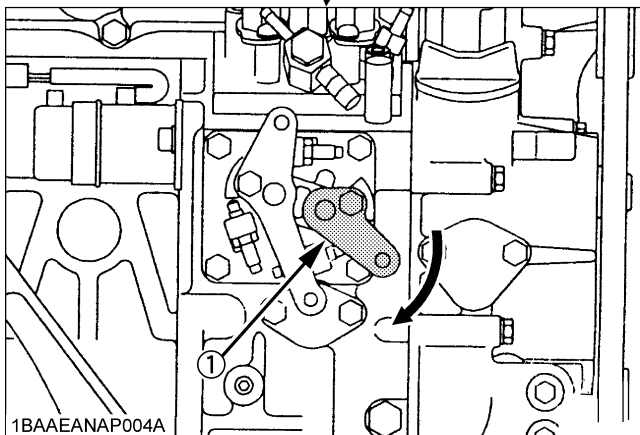
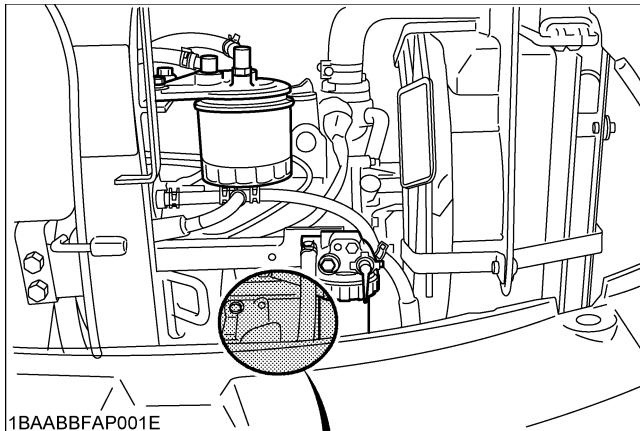

(1) Stop lever

STARTING WITH AN AUXILIARY BATTERY



CAUTION

To avoid personal injury:

- Battery gases can explode.
Do not smoke and keep sparks and flames away .
- Do not start the engine with an auxiliary battery if excavator battery is frozen.
- Do not connect the black jumper cable to the negative (-) terminal of the excavator battery.

■ Observe Following Guidelines when Starting with an Auxiliary Battery

1. Bring the helping machine with the same battery voltage as near as possible to the excavator.
THE MACHINES MUST NOT COME IN CONTACT WITH EACH OTHER.
2. Bring the levers and pedal of both vehicles in the neutral position and put the lock lever in the "Lock" position.
3. Wear eye protection and rubber gloves.
4. Remove the battery caps from both batteries. (If present)
5. Cover the battery opening with a cloth. Make sure that the cloth does not touch the battery terminals.
6. Connect the terminal of the red jumper cable with the plus (+) terminal of the low battery and connect the other end of the cable to the plus (+) terminal of the auxiliary battery.
7. Connect the black cable to the minus (-) terminal of the auxiliary battery.
8. Connect the other end of the black cable (coming from the auxiliary battery) to the excavator frame as far away as possible from the low battery.
9. Start the engine of the helping machine and let it run for a while. Start the excavator with the low battery.
10. Disconnect the jumper cables in the reverse sequence (Steps 8, 7, 6).
11. Remove the cloth and replace the vent caps.

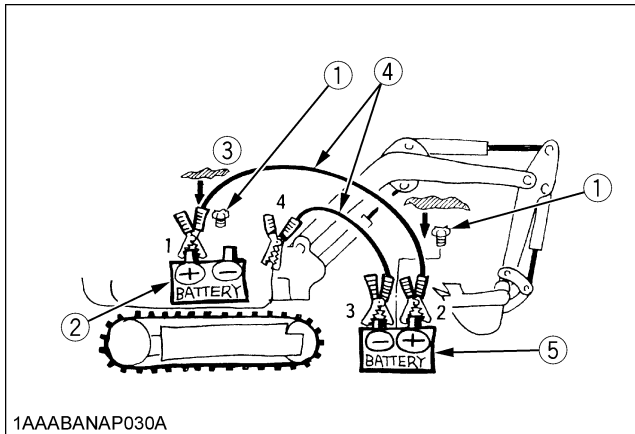

- (1) Remove battery caps (if present)
- (2) Low battery
- (3) Put a cloth over the battery openings
- (4) Jumper cables
- (5) Auxiliary battery

IMPORTANT :

- This excavator has a negative (-) earthed 12 Volt starting system.
- Only use the same voltage when using an auxiliary battery.
- Using a higher voltage will cause serious damage to the electrical system. When using an auxiliary battery, only the compatible (same) voltage is permissible.

EXCAVATOR OPERATION

RUNNING-IN OF THE NEW EXCAVATOR

The operation and care of the new excavator influences its life span. Your new excavator has been carefully checked and tested before leaving the factory. In spite of this, all movable components must run-in during the first 50 work hours. Do not work with full rpm's and full loads during this period. It is most important to run-in your excavator properly in order to achieve its full performance and longevity. During the running-in, the following points should be adhered to in all cases.

■ Do not Work with Full Engine Rpm's or Full Loads during the First 50 Working Hours

- Let the engine warm up sufficiently in the cold season.
- Do not let the engine rev-up more than necessary.

■ Oil Change in the Run-in Stage

The lubrication oil plays a specific and important role during the run-in phase of the excavator. The numerous movable parts are not yet run-in, so many fine metal particles are generated and cause damage and shorten the life of many components.

Pay attention to the oil-change intervals and complete them sooner than later. See the subject "Care and Maintenance" for more details on the oil-change intervals.

■ Seat Belt

WARNING

To avoid personal injury or death:

- Always use the seat belt with a ROPS/FOPS protection structure. Adjust the seat to the optimal position and buckle up.

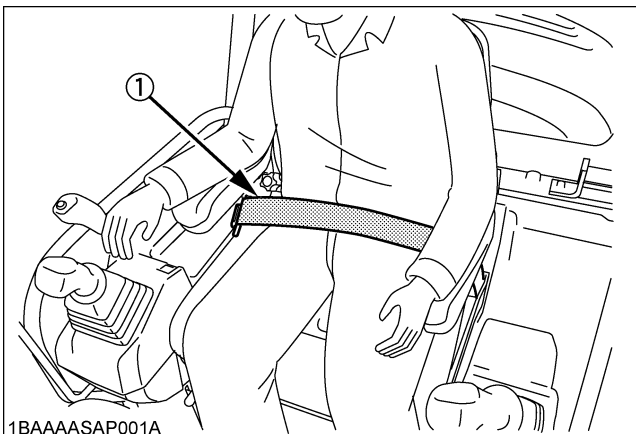

1BAAAASAP001A

(1) Seat belt

STARTING

CAUTION

To avoid personal injury:

- No persons, other than those familiar with the excavator, are allowed to use the excavator.
- Do not allow any person other than the operator to ride on the excavator.

■ Adjusting the Operator's Seat

CAUTION

To avoid personal injury:

- Before adjusting the operator's seat, make sure that no one puts hands on the engine bonnet behind the seat.
- After having adjusted the seat, make sure that the seat adjuster has clicked into position.
- Lock the lever for attachment control when adjusting the seat.

For and aft: While holding up the for-and-aft adjustment lever, reposition the seat for and aft.

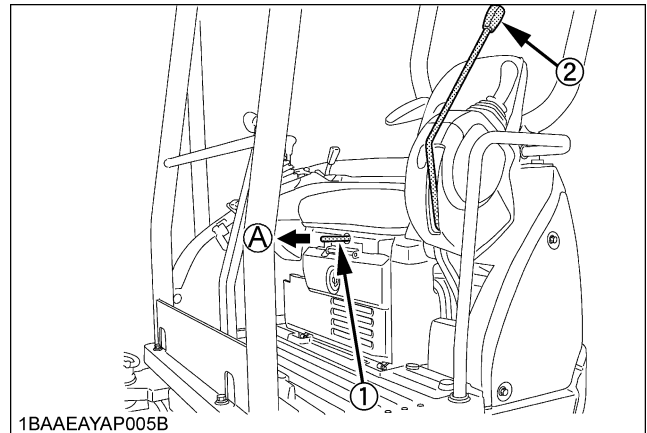

(1) For-and-aft adjustment lever

(A) "Unlock"

(2) Lock lever for attachment control

■ Lock Lever



CAUTION

To avoid personal injury:

- To avoid injuries, check safety features all around the excavator.

NOTE :

- With the lever lock pulled down, the engine fails to start.

If you try to start the engine with the key with the lock lever down, the following message appears momentarily on the meter display.



Lift up
unload lever

1BAAAAQAP0570

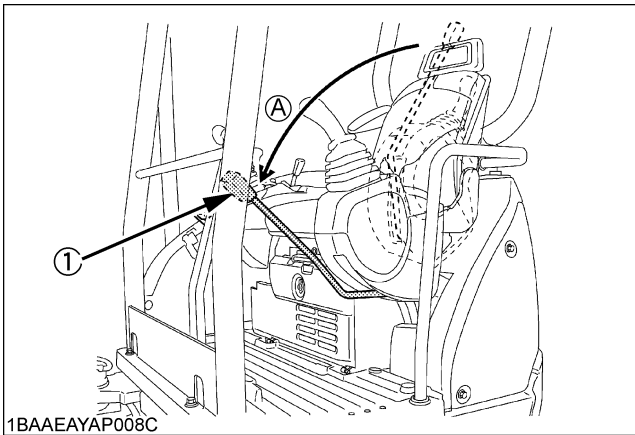

(1) Lock lever (Unload lever) (A) "Unlock"

■ Working Light Switch

When the starter switch is in position "RUN", the light(s) can be switched on by pressing the switch.

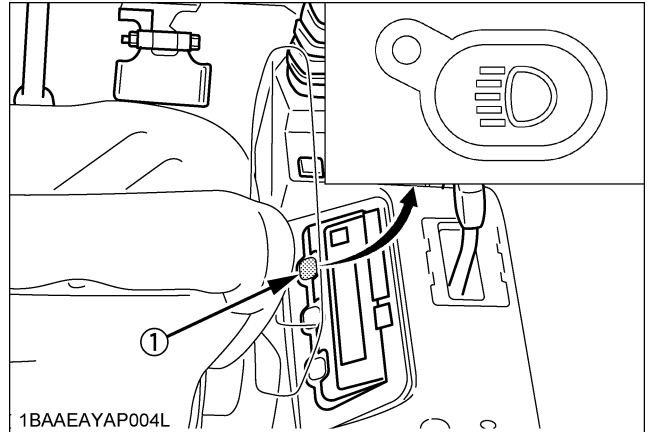

(1) Working light switch

◆ Night operation



CAUTION

To avoid personal injury:

- Visibility is reduced in darkness, therefore the work light alone may not be enough. In which case, prepare additional stationary artificial lighting, observe safety rules as well as special regulations for night work.

■ Travel Buzzer

When you handle the drive levers, the buzzer sounds at the same time or before the excavator starts to run.

TWO PATTERN SELECTION SYSTEM(TPSS)



CAUTION

To avoid personal injury:

- Study control lever pattern A and pattern B. Then choose the one which is most familiar
- Position the pattern selector lever (located on the right side of operator's seat) in either the lower position (pattern A) or the upper position (pattern B).
- Engage the lock lever to prevent accidental pattern change.
- Familiarize yourself with the pattern selected by operating slowly.

■ Pattern Change

1. Loosen the lever lock knob (2) and slide it to the direction (a), and position the pattern selector lever (1) to the desired position.
2. Slide the lever lock knob (2) to the direction (b) and tighten it.

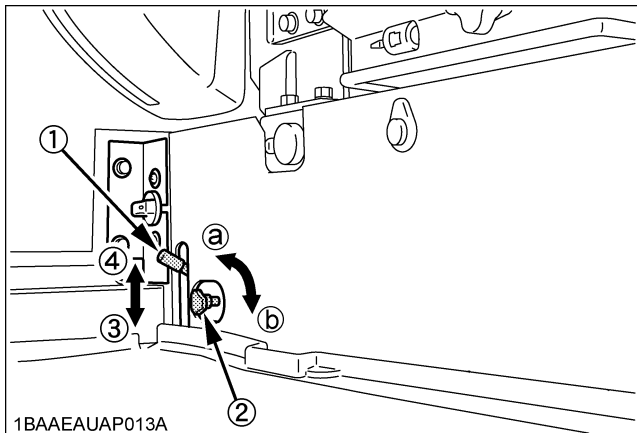

- (1) Pattern selector lever (Two Pattern Selection System:TPSS)
- (2) Lever lock knob
- (3) Pattern A
- (4) Pattern B
- (a) "UNLOCK"
- (b) "LOCK"

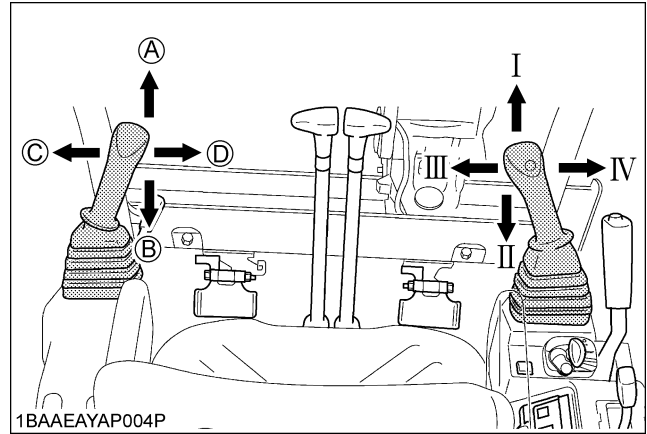

Lever Position		Pattern A	Pattern B
Attachment Control Lever (Left)	A	Boom down	Arm up
	B	Boom up	Arm crowd
	C	Swing left	Swing left
	D	Swing right	Swing right
Attachment Control Lever (Right)	I	Arm up	Boom down
	II	Arm crowd	Boom up
	III	Bucket crowd	Bucket crowd
	IV	Bucket dump	Bucket dump

OPERATION OF THE BOOM

To raise the boom, pull the attachment control lever back. The boom is equipped with a cushion cylinder which helps prevent excavated material in the bucket from falling out. Low hydraulic oil temperature, (e.g. after starting the engine in cold weather) the cushioning function will be effected for a short period of time (approx. 3 to 5 seconds). This condition results from the viscosity of the hydraulic oil and is not a sign of malfunction. The cushion cylinder will operate normally as the oil warms up. To lower the boom, push the attachment control lever forward.

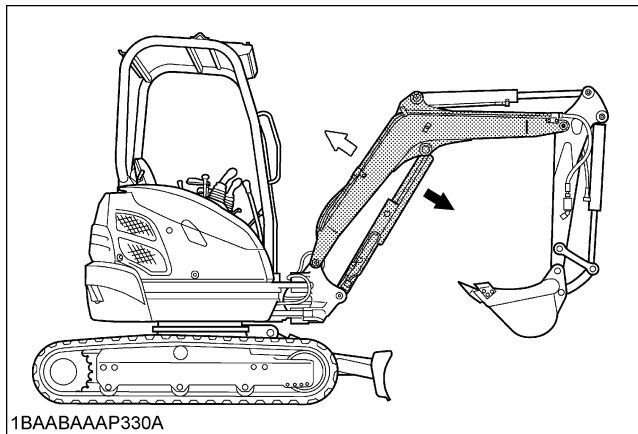
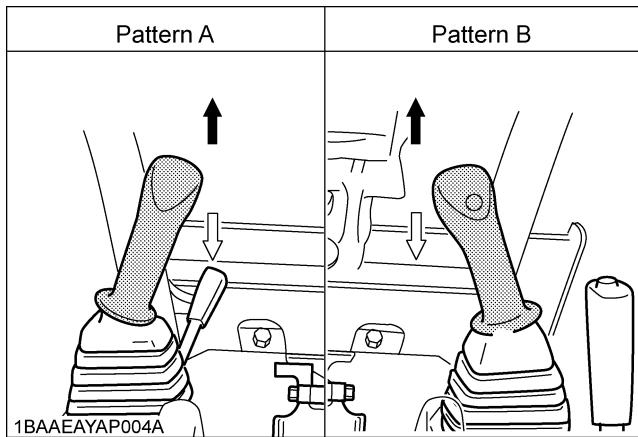

OPERATION OF THE ARM

Pull back the attachment control lever and the arm will be pulled in. To move the arm out, push the control lever towards the front.

NOTE :

- When pulling in the arm, the movement may stop for a short moment when the arm is in its vertical position. This is caused by the combined load of the arm and bucket moving the cylinder piston away from the hydraulic flow causing a delay in the cylinder action, until the flow catches up with cylinder piston. This is a characteristic of the hydraulic system and is no sign of a malfunction.

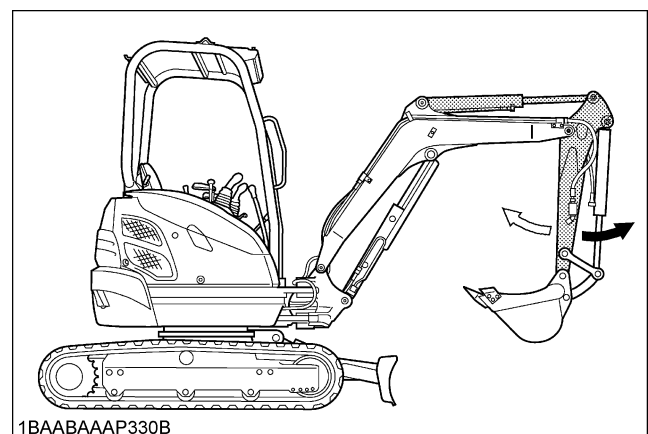
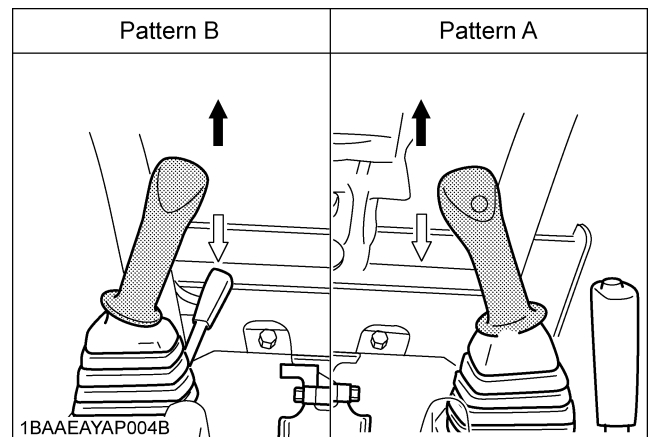

IMPORTANT :

- When lowering the boom, make sure that it does not hit the dozer and that the bucket teeth do not touch the dozer.

OPERATION OF BUCKET

To dig using the bucket, move the right attachment control lever from the neutral position, left. Moving the control lever right, moves the bucket outwards and dumps its contents.

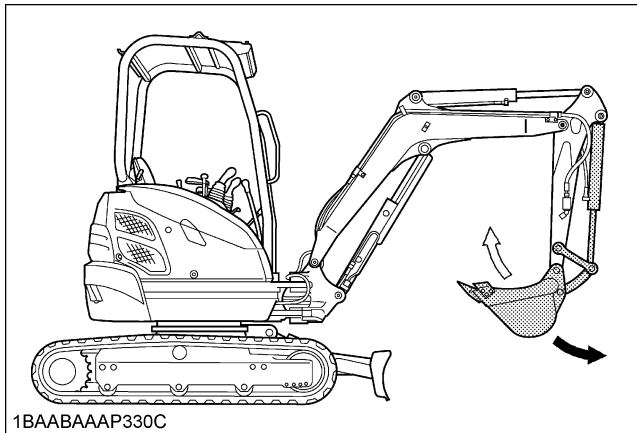
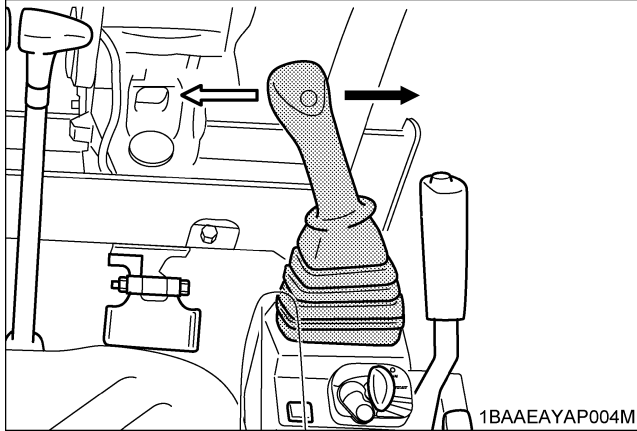

SWIVEL(UNIT SWING)OPERATION



CAUTION

To avoid personal injury:

- When working in groups, always let the others know what you are going to do before you do it.
- Keep away from the working area.

IMPORTANT :

- Do not operate the left attachment control lever abruptly from right to left (or vice versa). Because of the low of inertia, this causes an impact load on the swing gear and the swing motor. Additionally, the life of the excavator will be shortened.
- Unlock the swing lock pin before doing swivel operations.

1. Move the control lever to the left and the upper structure will turn to the left.
2. Move the control lever to the right and the upper structure will turn to the right.

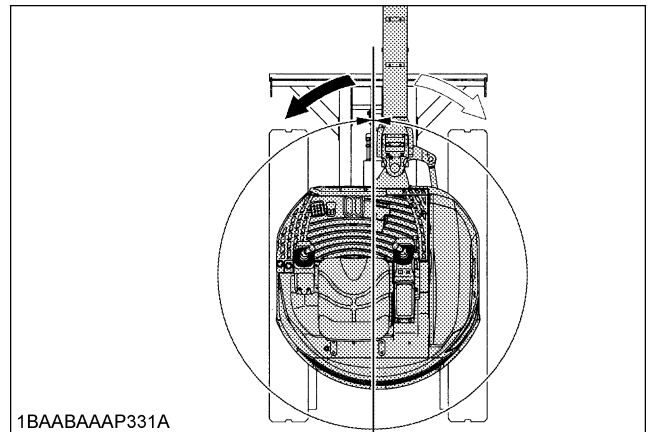
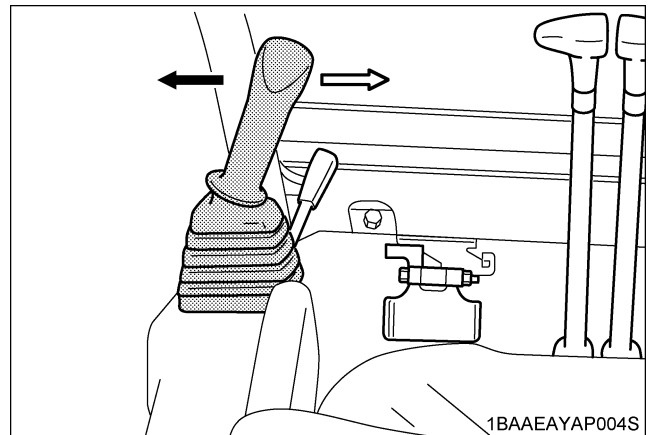

BOOM SWING OPERATION

1. Flip the pedal lock up to unlock the pedal.
2. Step on the left side of the pedal (→) to swing the boom to the left.
3. Step on the right side of the pedal (⇐) to swing the boom to the right.

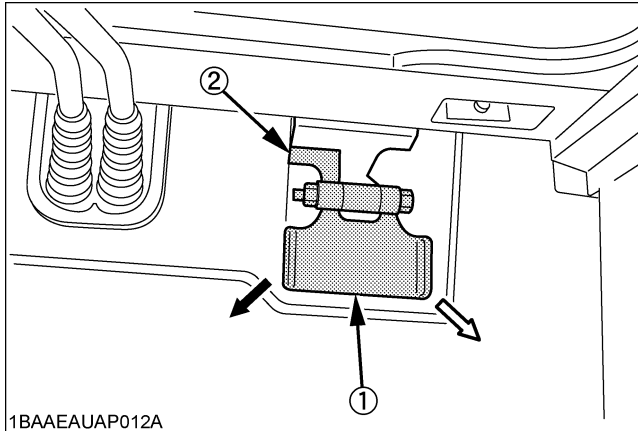

- (1) Boom swing pedal
(2) Pedal lock

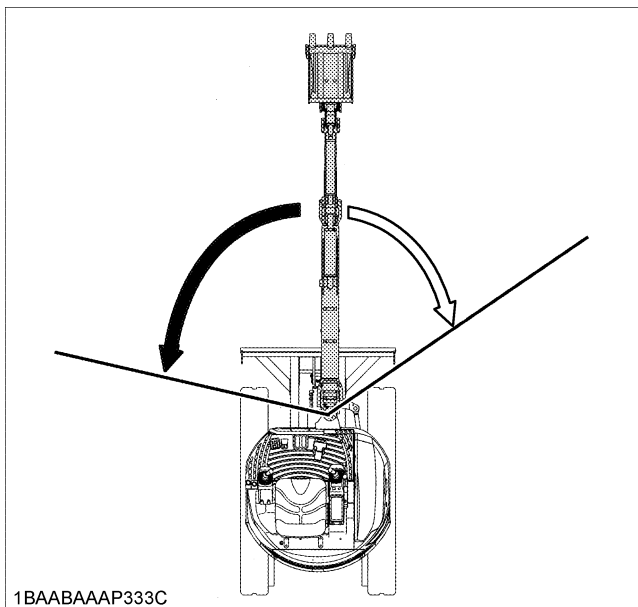

OPERATION OF THE DOZER

1. To raise the dozer, pull back the control lever. Pushing the control lever forwards lowers the dozer.

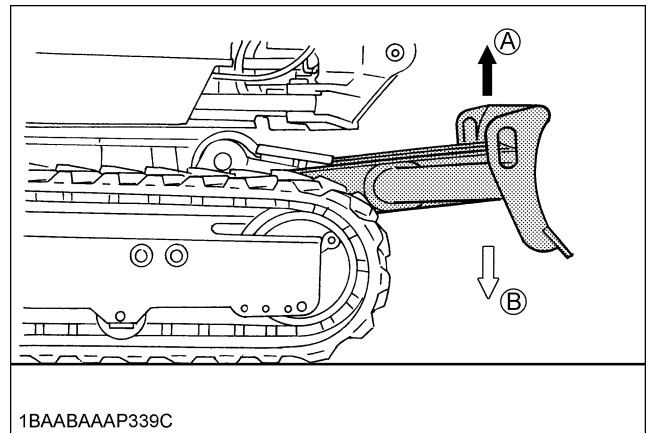
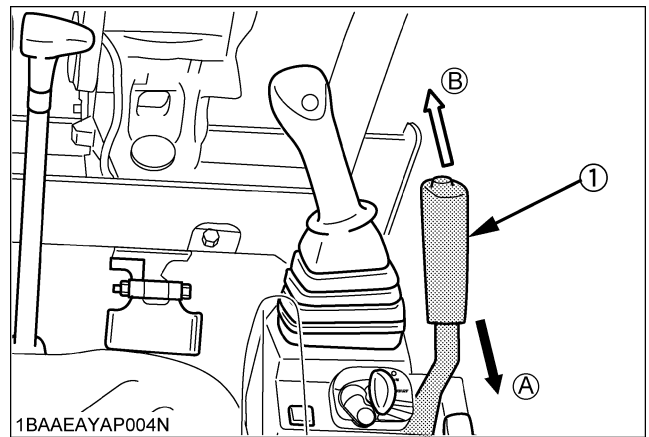

- (1) Control lever
(A) "Raise"
(B) "Lower"

2. While undertaking earth moving work, control both drive levers with left hand and the dozer control lever with right hand.

SERVICE PORT OPERATION



CAUTION

To avoid personal injury:

- Tilt the service port pedal forward when the pedal is not used. Be sure to lock the pedal.

This pedal is used to operate attachments such as breakers.

IMPORTANT :

- When the service port is not used for a long period, dirt particles can settle in the lower part of the service port lines. When the plugs on the service port lines are removed to connect attachments, drain approx. 100 cc of oil per side. For breaker choices, contact your dealer.

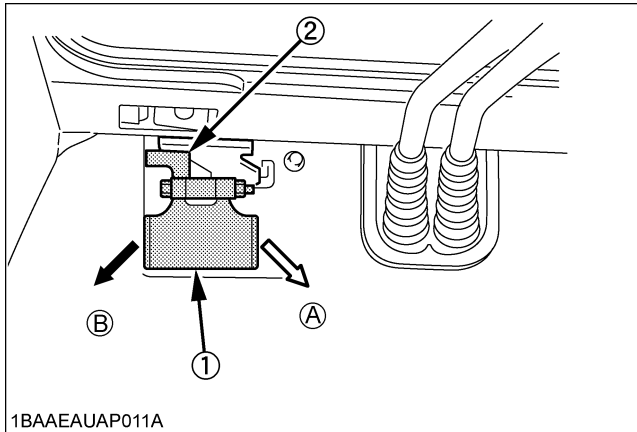

1BAAEUAP011A

- (1) Service port pedal (A) Sends oil to the port (A)
 (2) Pedal lock (B) Sends oil to the port (B)

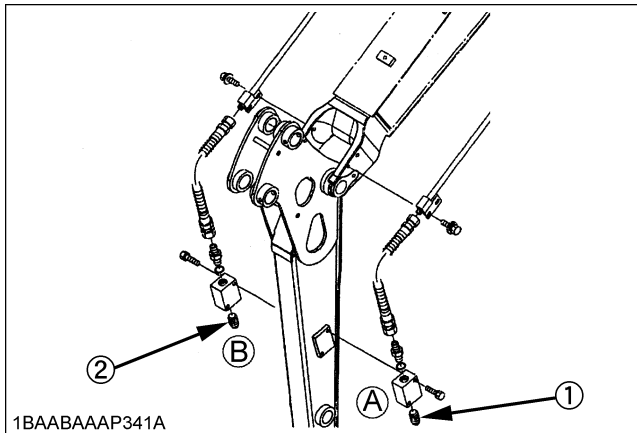

1BAABAAP341A

- (1) Port (A)
 (2) Port (B)
- Push the right part of the pedal (↘) to send oil to the port (A).
 - Push the left part of the pedal (↙) to send oil to the port (B).

Max. Flow Volume Theoretical L/min.	48.0
Max. Pressure MPa (kgf/cm ²)	21.6 (220)

DRIVING



WARNING

To avoid personal injury or death:

- Before starting the engine, make sure that no one is near the excavator.
- Before operating the excavator, check the track direction. (Idler and dozer to the front of the excavator).

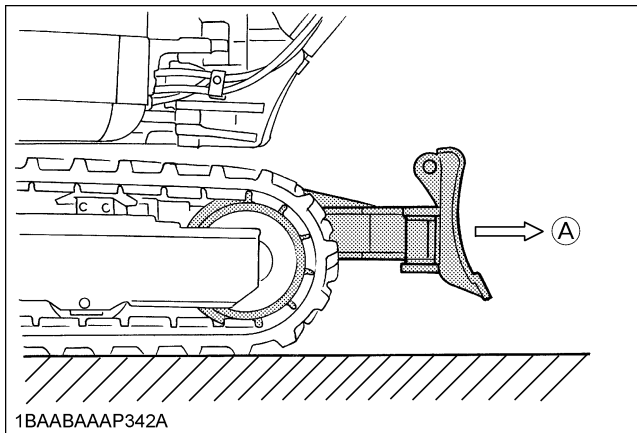

1BAABAAAP342A

(A) "Front"

1. To lock the swing frame with the track frame, engage the swing lock pin.
2. Adjust the engine speed from idling to an intermediate speed.
3. Unlock the lock lever for attachment control.
4. Raise the dozer and hold the bucket about 20 to 40 cm over the ground.

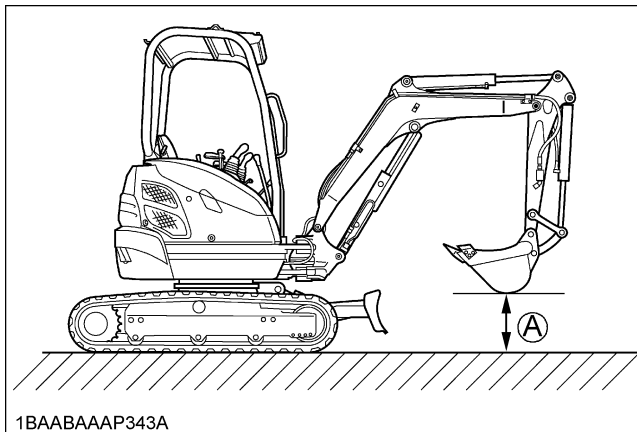

1BAABAAAP343A

(A) 20 to 40 cm

Drive Levers (Right, Left)



WARNING

To avoid personal injury or death:

- If the swing frame has been turned 180°, i.e. the dozer is, seen from the operator, "behind", then the travel direction is opposite to the drive direction of the levers (when activating the drive lever forwards, the excavator, seen from the operator, will move backwards).

Pushing the drive lever forward, moves the excavator forward, and vice-versa. The front of the excavator is the direction where the dozer is present.

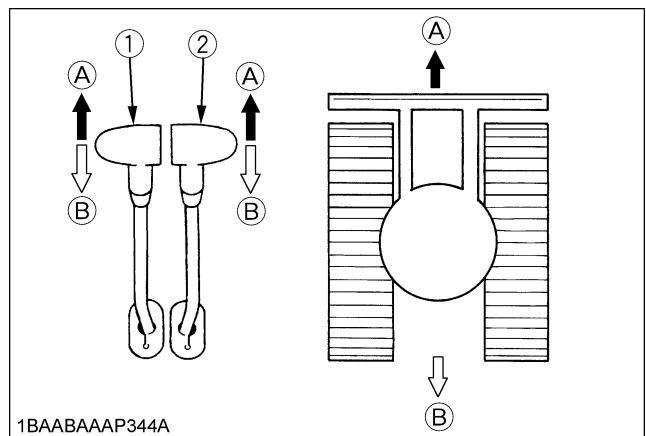

1BAABAAAP344A

- (1) Drive lever (left)
- (2) Drive lever (right)

- (A) "Forward"
- (B) "Backward"

IMPORTANT :

- If the tracks are clogged with sand or gravel while working on soft ground, lift up one track with the help of the boom, arm and bucket and let the track rotate to shake off the sand and gravel.



WARNING

To avoid personal injury or death:

- When lifting the machine with an attachment, place a safety block or safety post to prevent the machine from turning over. Keep the lock lever for attachment control in the "LOCK" position.

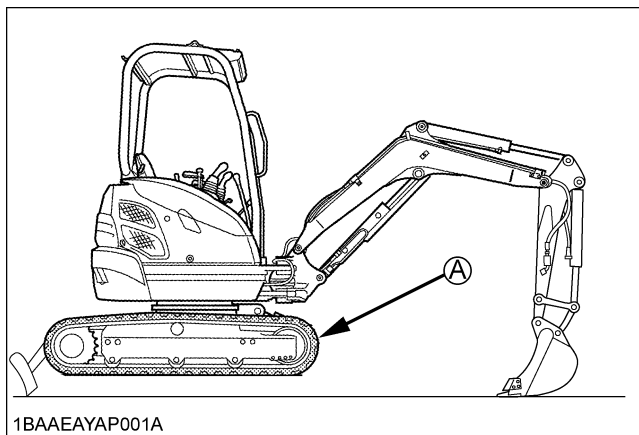



1BAAEAYAP001A

(A) "Rotate to shake off sand and gravel"

Travel Speed Switch

Travel speed will increase when this switch is pushed down.

Switching the dual travel speed:

1. Press the travel speed switch. The buzzer beeps and the travel speed changes from first speed to second. The  symbol lights up.
2. Press the travel speed switch again, and the buzzer beeps and the travel speed changes from second speed to first. The  symbol light goes out.

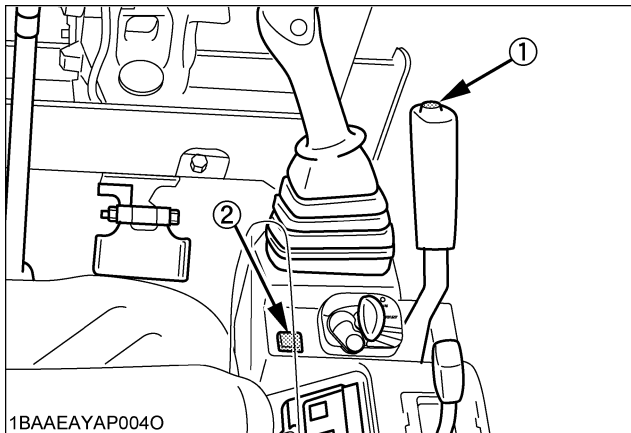

1BAAEAYAP004O

- (1) Travel speed switch
(2) Speed indicator light

NOTE :

- When activating the travel speed switch, it must be pushed down completely.
- Each time the travel speed switch is pressed, the travel speed is switched between first and second.

IMPORTANT :

- Do not activate the travel speed switch when there is increased drive resistance (e.g. driving on inclines or on uneven grounds).

TURNS



CAUTION

To avoid personal injury:

- Do not change direction on steep slopes, or the excavator could tip over.
- Before changing direction, beware of people in the work area.

■ Pivot Turn

NOTE :

- Movement as illustrated shows the turning directions with the dozer in the front.

◆ Change of Direction while Stationary

1. Push the left drive lever forward; the excavator will turn in the direction of the arrow of the illustration below.

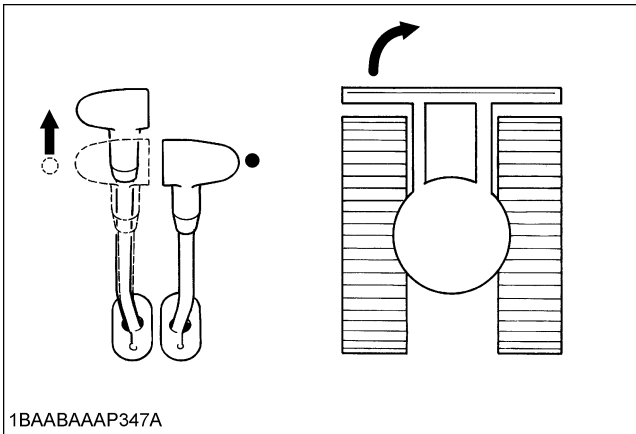

2. Pull the left drive lever backward; the excavator will turn in the direction of the arrow of the illustration below.

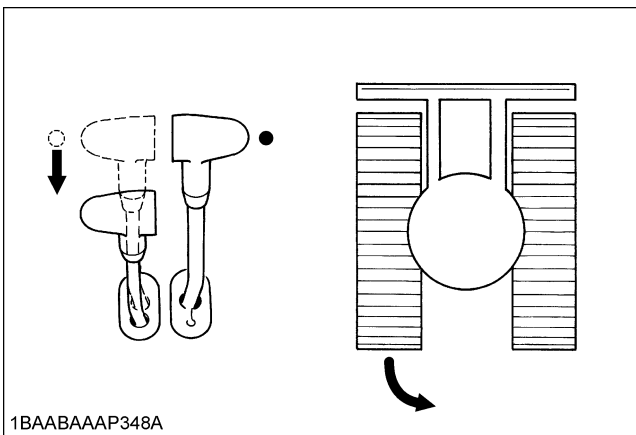

◆ Change of Direction while Travelling

1. While travelling forwards, bring the left drive lever in the neutral position; the excavator will turn in the direction of the arrow of the illustration below.

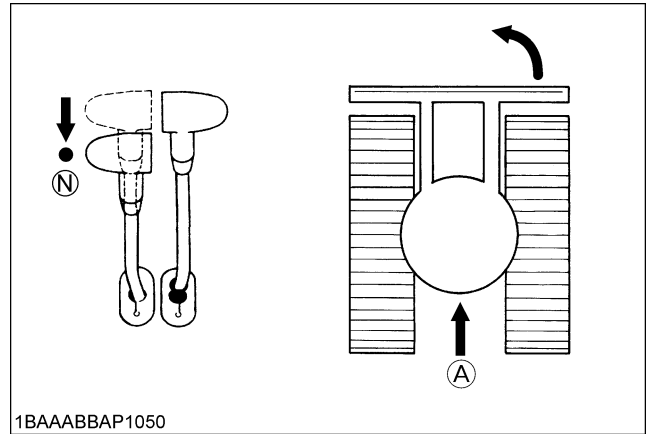

(A) "Travelling forward"
(N) "Neutral position"

2. While travelling backwards, bring the left drive lever in the neutral position; the excavator will turn in the direction of the arrow of the illustration below.

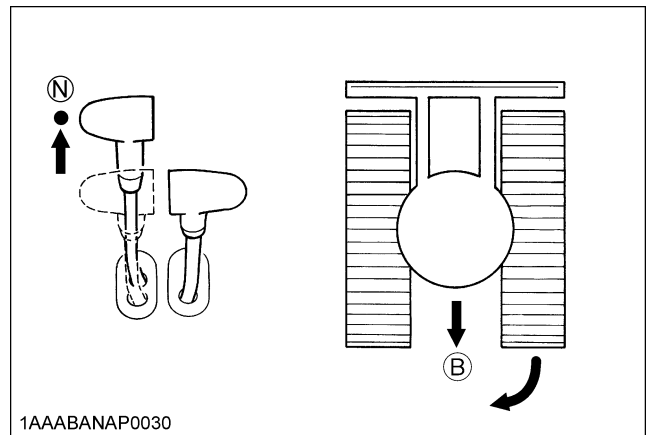

(B) "Travelling backward"
(N) "Neutral position"

■ Spin Turn

When both drive levers are activated in the opposite directions, both track will rotate with the same speed but in opposite directions. The center of rotation is the center of the excavator.

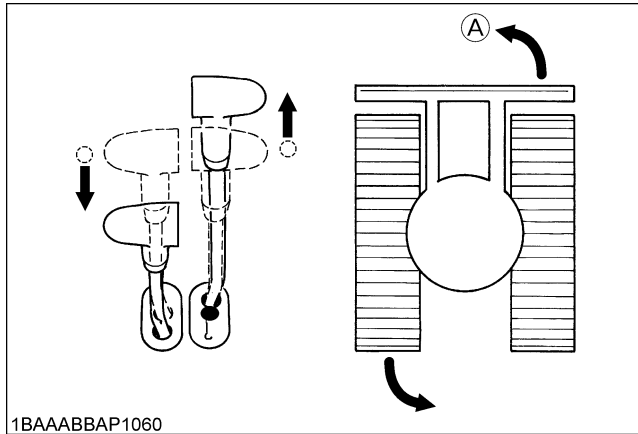

1BAAABBAP1060

(A) "Left spin turn"

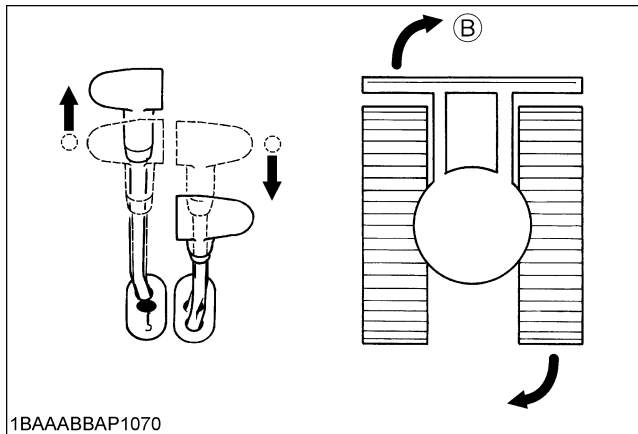

1BAAABBAP1070

(B) "Right spin turn"

UP AND DOWNHILL TRAVELLING



CAUTION

To avoid personal injury:

- When travelling up or down a slope, use extra caution and follow the instructions below.

While travelling uphill, keep the lower edge of the bucket approx. 20 to 40 cm above the ground. Although the KUBOTA excavator will not slip easily because of the tracks, it is safer to let the bucket slide over the ground while travelling downhill.

Always choose slow speed for uphill and downhill travelling.

[UPHILL TRAVELLING]

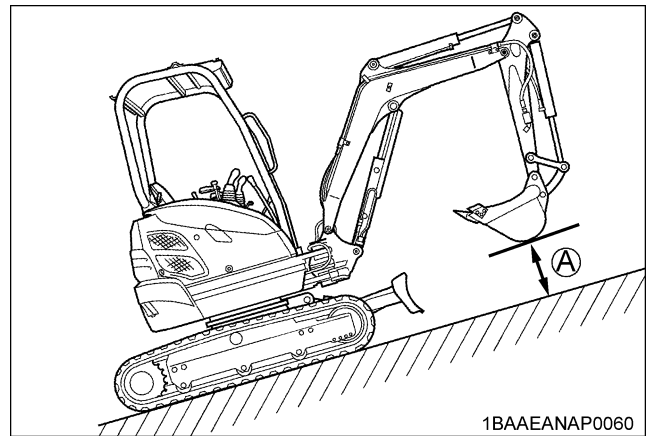

1BAAEANAP0060

(A) 20 to 40 cm

[DOWNHILL TRAVELLING]

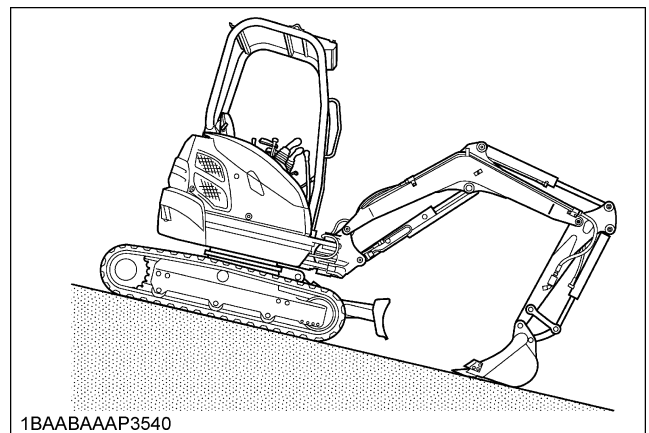

1BAABAAP3540

PARKING ON A SLOPE



WARNING

To avoid personal injury or death:

- When the excavator is parked or left unattended on a slope, be sure to put the bucket on the ground and place all control levers in neutral position, then brace the tracks with chocks.

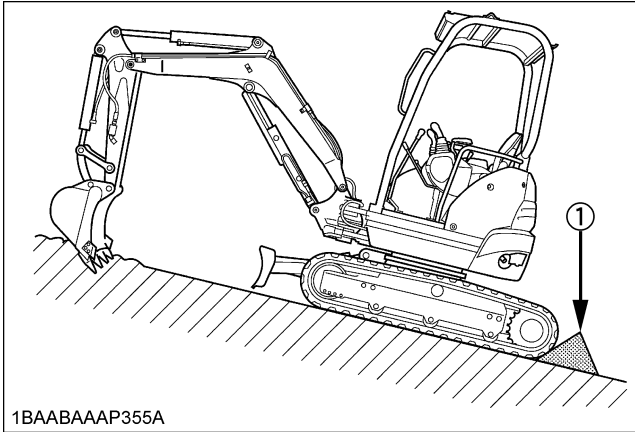

1BAABAAAP355A

(1) Chock

IMPORTANT INFORMATION ON EXCAVATOR OPERATION

- Do not try to crush concrete or boulders using side swings with the bucket. Also avoid using side sweeps of the bucket to move earth piles.
- Under all circumstances avoid the following operations:
 - Excavation using the gravitational impact of the machine.
 - Compacting of gravel or soil using the dropping action of the bucket.
 - Excavation using the traveling power of the machine.
- Do not try to drop or shake off soil adhering to the bucket in the manner given in the points below. This can cause damage to the machine. Adhering soil can be shaken off when the bucket is being emptied by moving the bucket out to the maximum stroke of the cylinder. Should this not suffice, swing out the arm as far as possible and operate the bucket back and forth.
- Do not hit the dozer with the boom cylinder! Make sure that the boom cylinder does not hit the dozer when doing deep excavation. If necessary swing around so that the dozer is in the back of the machine.
- Pay attention when pulling in the bucket! When pulling in the bucket (for driving or transportation) avoid hitting the dozer.
- Avoid collisions! When moving the excavator, pay attention that the dozer does not collide with obstructions such as boulders etc.. Such collisions shorten the life of the dozer and the cylinder substantially.
- Support the machine correctly! When stabilizing the machine with the dozer, lower the dozer to engage the full width on the ground.
- If the water or mud level reaches higher than the top of the tracks, the swivel bearing, swivel motor gear and ring gear may be exposed to mud, water and other foreign objects. The excavator must be properly pressure washed after each use.
 - Thoroughly clean the area around the swivel bearing, swivel motor gear and ring gear to remove foreign objects.
 - Inspect the swivel motor oil sump (if equipped) for water contamination. If water is present, refer to operator's manual for lubricant replacement procedure.
 - Refer to operator's manual for proper swivel bearing, swivel motor gear and ring gear lubrication procedures.
 - Reinstall any protective covering if removed earlier.

TRANSPORTING THE EXCAVATOR ON A TRUCK



DANGER

To avoid personal injury or death:

- No directional changes should be made when the excavator is on the ramp. Should a change of direction be necessary, drive off the ramp completely and make the turn.
- When driving forwards or backwards onto the truck, or when swinging the upper body, make sure that neither the cabin or the gates of the truck will be damaged.

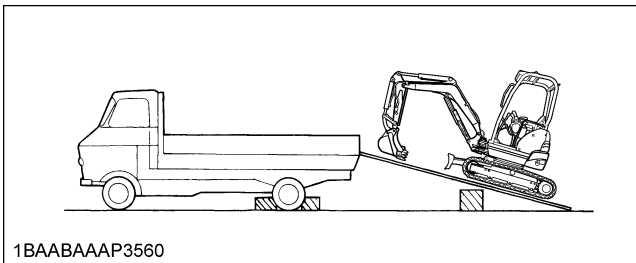

1BAABAAAP3560

- When the excavator reaches the point between the ramps and the truck bed, halt and then move very slowly until the excavator reaches the horizontal position.
- Move the excavator onto the truck only with the arm completely pulled in. Otherwise the truck cabin could be damaged when swinging around the upper body.
- Do not jack up the machine using its boom to load or unload the excavator from the truck. Dangerous situation could arise.

■ Transporting on a Truck



WARNING

To avoid personal injury or death:

- After loading the machine on the truck, lower the bucket and dozer onto the truck bed.

Prepare a platform to load or unload the excavator. Take following steps when using ramps.

1. Apply the parking brakes of the truck, and block the drive wheels from both sides.

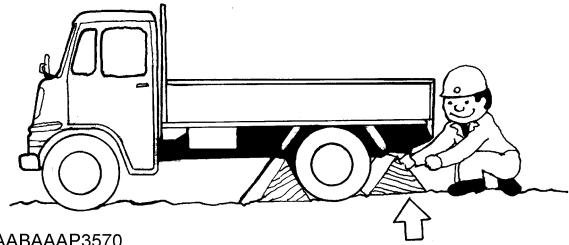

1BAABAAAP3570

2. Use mounting brackets to secure the ramp properly. Connect the ramps directly to the truck bed.

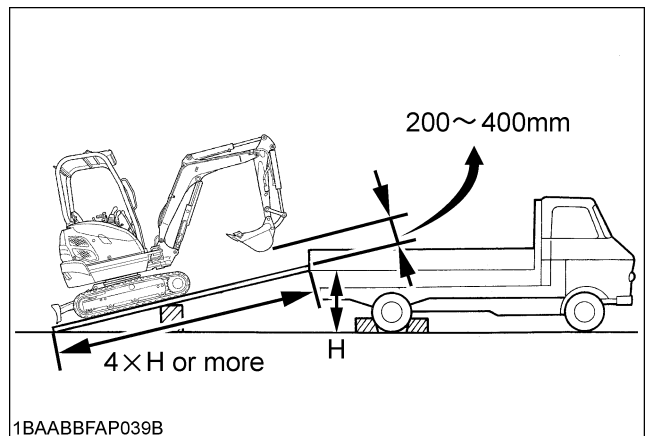

1BAABBFAP039B

3. For additional safety, use blocks or supports under the ramps and the truck bed.

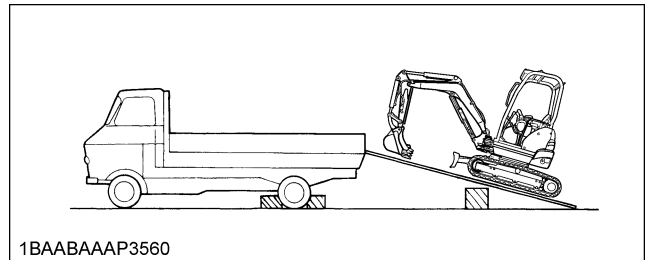

1BAABAAAP3560

4. Align the ramps and the tracks and then drive the excavator slowly up the ramps with the dozer in the front. After ensuring that the tracks are completely on the truck bed, swivel the upper body around to the back of the truck.

5. Block the tracks and tie down the excavator with suitable chains and approved method (check appropriate state regulation).

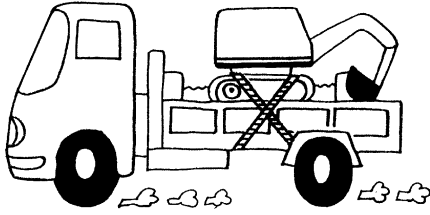

1AAABANAP032A

6. Before unloading, remove the swing lock pin and then raise the dozer and bucket from the truck bed.

LIFTING OF THE EXCAVATOR



DANGER

To avoid personal injury or death:

- The correct instructions for safe handling are described here. Read these instructions carefully before moving the machine. Make sure that the operating personnel read the operator's manual carefully.

■ Basics when Lifting with Cables or Straps

1. The lifting and crane operation is to be undertaken according to the guidelines described.
2. The equipment used for lifting mentioned in these instructions are only given as reference, the standards concerning strength, control and other details are based on the respective applicable guidelines.

■ Safety Aspects when Lifting with Cables or Straps

Abide by following steps when lifting:

1. Do not lift loads that exceed the maximum load capacity of the crane.
2. Choose correct equipment suitable to the weight, size and form of the load.
3. First assess the center of gravity of the load, position the hook directly over the load and lift the load so that the center of gravity of the load is as low as possible.
4. The steel cables or straps must be fixed in the middle of the hook.
5. The load must be lifted vertically from the ground.
6. Do not enter the working area under suspended loads and do not move the load over people. The load must only be moved in an area where the balance can be easily maintained.

■ Lifting Procedure for the Excavator



WARNING

To avoid personal injury or death.

- Do not use the hooks on the roof of canopy and cabin for lifting the excavator.

◆ General guidelines for lifting

1. Lifting position. (see illustration)
 - (1) Pull in the boom towards rear.
 - (2) Pull in the arm completely.
 - (3) Pull in the bucket completely.
 - (4) Adjust the swing angle to the center. (to bring the boom in a position parallel to the machine frame)
 - (5) Swing frame so that dozer blade is to the rear and frame is parallel with tracks.
 - (6) Raise the dozer blade fully.
2. Attaching the steel cables or straps.

- (1) Always hook the excavator at three points. (one on the boom and right and left of the dozer)
- (2) Always use a shackle on each lifting hole when attaching the cables or straps.
- (3) Use protective material at all places where the cables or straps contact the machine.
- (4) Keep the angle between the front and rear cables or straps within 30° (0.52 rad.).

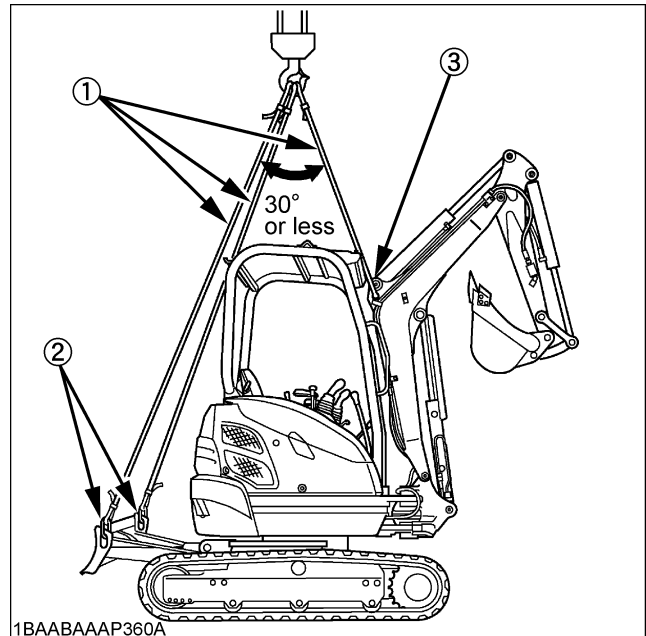

- (1) Steel cable
- (2) Shackle
- (3) Protective material

3. Tackle

The weights of the excavators and the recommended tackle for lifting these loads are mentioned in the following table. Choose components having enough strength.

Excavator Weight*	2540 kg
Load / Cable	8500 N (866.7 kgf)
Minimum Cable Diameter (Safety factor=6)	12.5 mm or more

*Excavator Weight: With canopy, steel tracks.

Steel cable: 6X24

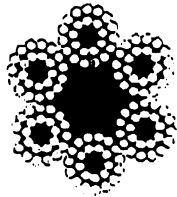

1AAABANAP034A

4. Lifting

- (1) Lift slowly and safely
- (2) Do not enter the excavator area when lifting.
- (3) Lift the excavator horizontally. (Modify cable or strap connections according to needs)

Maximum strength

for example: (JIS G 35 25) - "6X24"

Diameter	zinc-plated	not zinc-plated
10 mm (3/8)	45.8 kN (4670 kgf)	49.3 kN (5027 kgf)
12.5 mm (1/2)	71.5 kN (7290 kgf)	77 kN (7851 kgf)
14 mm (9/16)	89.7 kN (9146 kgf)	96.6 kN (9850 kgf)
16 mm (5/8)	117 kN (11930 kgf)	126 kN (12848 kgf)
18 mm (45/64)	148 kN (15091 kgf)	160 kN (16315 kgf)

MAINTENANCE

MAINTENANCE INTERVALS

No.	Check points		Intervals	Hour meter indicator							Consequently	Ref. page				
				50	100	150	200	250	300	350					400	450
1	Coolant		check	Daily check								39				
			change									every 2 years	54			
2	Fuel		check	Daily check								37				
3	Engine oil		check	Daily check								38				
			change	●					○			every 250 hrs	47			
4	Hydraulic oil		check	Daily check								38				
			change									every 1000 hrs	52	*1		
5	Lubrication points		-	Daily check								39				
6	Radiator and oil cooler		check	Daily check								40				
7	Engine and electrical wiring		check	Daily check							every year	41				
8	Fuel tank, Water separator		drain	○	○	○	○	○	○	○	○	○	every 50 hrs	42,42		
9	Battery condition		check	○	○	○	○	○	○	○	○	○	every 50 hrs	43		
10	Greasing swing bearing teeth		-	○	○	○	○	○	○	○	○	○	every 50 hrs	44		
11	Fan belt tension		check	Daily check								40				
			adjust				○				○		every 200 hrs	45		
12	Radiator hoses and clamps		check				○				○		every 200 hrs	45		
			replace											every 2 years	54	
13	Air filter element	Outer element	clean				○				○		every 200 hrs	46	*2	@
		Inner element	replace										every 1000 hrs	53	*2	
			replace											every 1000 hrs	53	
14	Greasing swing ball bearings		-				○				○		every 200 hrs	46		
15	Fuel filter cartridge		replace										every 500 hrs	50		@
16	Engine oil filter		replace	●						○			every 250 hrs	48		
17	Drive unit oil		change		●								every 500 hrs	49		
18	Hydraulic return filter element		replace				●						every 500 hrs	50		
19	Hydraulic suction filter element		replace										every 1000 hrs	52		
20	Filter in the pilot hydraulic system		replace										every 1000 hrs	51		
21	Fuel injection nozzle injection pressure		check										every 1500 hrs	53	*4	@
22	Front idler and track roller oil		change										every 2000 hrs	53		
23	Alternator and starter motor		check										every 2000 hrs	53		
24	Injection pump		check										every 3000 hrs	53	*4	@
25	Radiator system		rinse										every 2 years	54		
26	Fuel line and Intake air line		check				○				○		every 200 hrs	47		@
			replace										every 2 years	55	*3	
27	Greasing pilot valve linkage		-				○						every 250 hrs	49		
28	Pilot circuit filter		clean										every 1000 hrs	51		

* 500 thru 1000 continued to the following table.

No.	Check points		Intervals	Hour meter indicator							Consequently	Ref. page				
				500	550	600	650	700	750	800					1000	
1	Coolant		check	Daily check								39				
			change									every 2 years	54			
2	Fuel		check	Daily check								37				
3	Engine oil		check	Daily check								38				
			change		○					○		every 250 hrs	47			
4	Hydraulic oil		check	Daily check								38				
			change								○	every 1000 hrs	52	*1		
5	Lubrication points		-	Daily check								39				
6	Radiator and oil cooler		check	Daily check								40				
7	Engine and electrical wiring		check	Daily check							every year	41				
8	Fuel tank, Water separator		drain	○	○	○	○	○	○	○	○	○	every 50 hrs	42,42		
9	Battery condition		check	○	○	○	○	○	○	○	○	○	every 50 hrs	43		
10	Greasing swing bearing teeth		-	○	○	○	○	○	○	○	○	○	every 50 hrs	44		
11	Fan belt tension		check	Daily check								40				
			adjust			○					○	○	every 200 hrs	45		
12	Radiator hoses and clamps		check			○					○	○	every 200 hrs	45		
			replace											every 2 years	54	
13	Air filter element	Outer element	clean			○					○	○	every 200 hrs	46	*2	@
			replace									○	○	every 1000 hrs	53	
		Inner element	replace									○	○	every 1000 hrs	53	
14	Greasing swing ball bearings		-			○					○	○	every 200 hrs	46		
15	Fuel filter cartridge		replace	○								○	every 500 hrs	50		@
16	Engine oil filter		replace		○						○		every 250 hrs	48		
17	Drive unit oil		change			○							every 500 hrs	49		
18	Hydraulic return filter element		replace							○			every 500 hrs	50		
19	Hydraulic suction filter element		replace								○		every 1000 hrs	52		
20	Filter in the pilot hydraulic system		replace								○		every 1000 hrs	51		
21	Fuel injection nozzle injection pressure		check										every 1500 hrs	53	*4	@
22	Front idler and track roller oil		change										every 2000 hrs	53		
23	Alternator and starter motor		check										every 2000 hrs	53		
24	Injection pump		check										every 3000 hrs	53	*4	@
25	Radiator system		rinse										every 2 years	54		
26	Fuel line and Intake air line		check			○					○	○	every 200 hrs	47		@
			replace											every 2 years	55	
27	Greasing pilot valve linkage		-	○							○	○	every 250 hrs	49		
28	Pilot circuit filter		clean										every 1000 hrs	51		

IMPORTANT :

● First operation

*1 When using a hydraulic breaker, change hydraulic oil and return filter according to the table on "Hydraulic Oil Change (Including Exchange of the Suction Filter in the Hydraulic Tank) under "EVERY 1000 SERVICE HOURS" in the chapter "REGULAR CHECKS AND MAINTENANCE WORK".

*2 Clean and replace the air filter more frequently if used under dusty conditions. When the filter is very dirty from dusty conditions, replace the filter.

*3 Replace only if necessary.

*4 Consult your local KUBOTA Dealer for this service.

- The items listed above (@ marked) are registered as emission related critical parts by KUBOTA in the U.S.EPA non-road emission regulation. As the engine owner, you are responsible for the performance of the required maintenance on the engine according to the above instruction. Please see the Warranty Statement in detail.

DAILY CHECKS

For your own safety and to assure the long life of your machine, a careful check should be made before each operation.

■ Check Fuel Level



CAUTION

To avoid personal injury:

- Stop the engine and remove the key before fuelling.
- Do not smoke while fuelling.

IMPORTANT :

- By temperatures over -5°C (23°F), use No.2-D diesel fuel, when temperatures are under -5°C (23°F), use No.1-D diesel fuel.
- Make sure that the fuel tank is not run empty. Air will enter the fuel system, and must be purged before restarting.
- See "PURGING OF THE FUEL SYSTEM" in "OTHER ADJUSTMENTS AND REPLACEMENTS"
- To prevent condensation (water) accumulations in the fuel tank, fill the fuel into the tank before parking overnight.

1. Check the fuel level by the fuel level indicator.

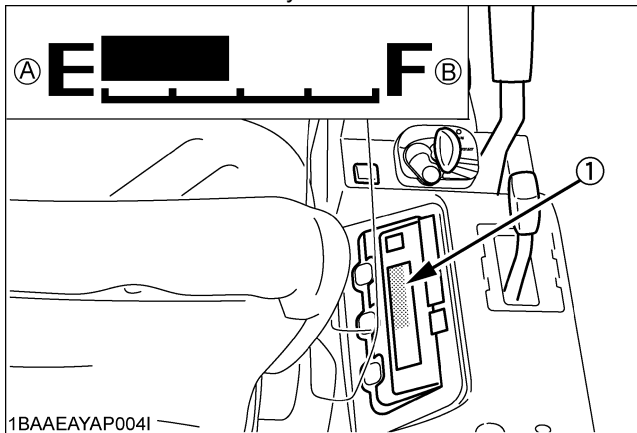

(1) Fuel gauge

(A) "EMPTY"

(B) "FULL"

2. If necessary, open the tank cover with the starter key, open the cap and add fuel.

- See "Opening and Closing of the Fuel Tank Cap" and see Fuel supply in the "LCD Display for Normal Operation" section.

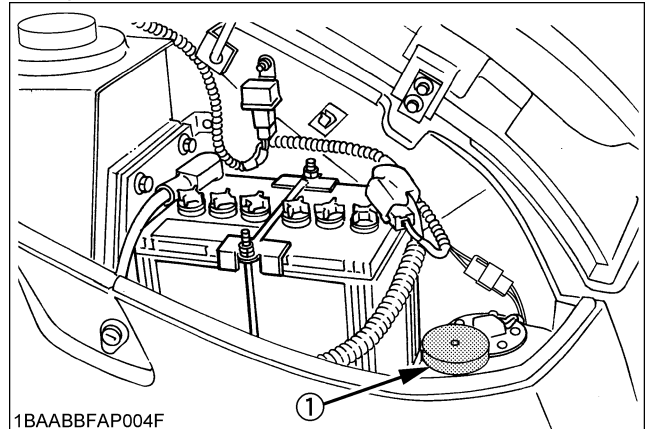

(1) Fuel tank cap

Fuel tank capacity	28 L
--------------------	------

■ Check Engine Oil Level

CAUTION

To avoid personal injury:

- Stop the engine and remove the key before checking the oil level.

IMPORTANT :

- Use engine oil with the correct viscosity. (according to the outside temperature)
- After stopping the engine and remove the key, wait five minutes, then check oil level. (Excavator must be on level ground.)

Insert the engine oil dipstick fully into the prepared opening, remove again and check the oil level; if necessary fill with oil. The machine must be on level ground when checking the oil level.

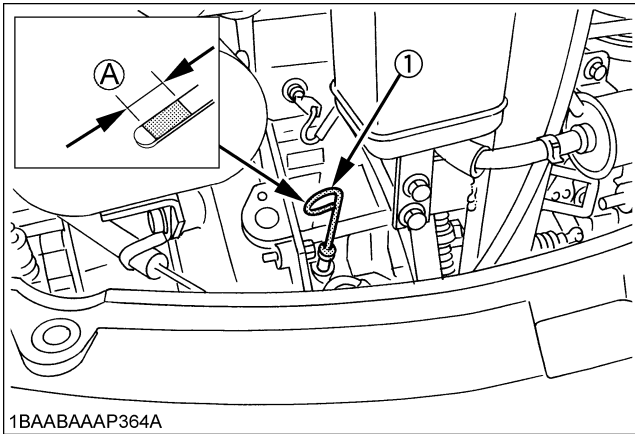

1BAABAAAP364A

(1) Engine oil dipstick (A) Required level

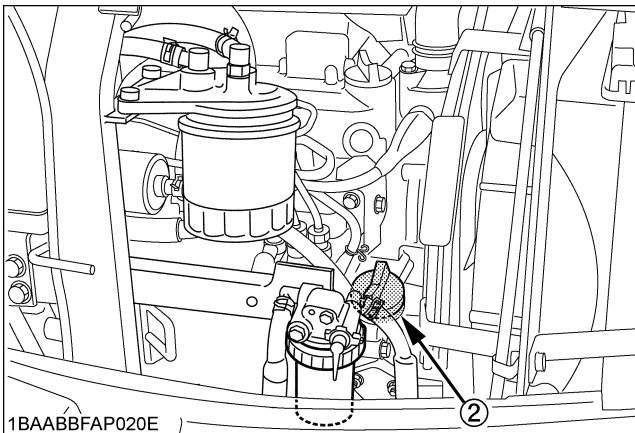

1BAABBFAP020E

(2) Oil filling port

■ Check Hydraulic Oil Level

CAUTION

To avoid personal injury:

- Stop the engine and remove the key before checking the oil level.

IMPORTANT :

- Before filling oil, wipe away all sand and dust from around the oil port. Make sure to use an identical type of hydraulic fluid.
- The excavator has been filled with hydraulic fluid before delivery. See "RECOMMENDED OILS". (Do not mix different oils)

1. Park the excavator on a firm, flat and level surface. Lower the attachments and dozer blade to the ground and stop the engine.

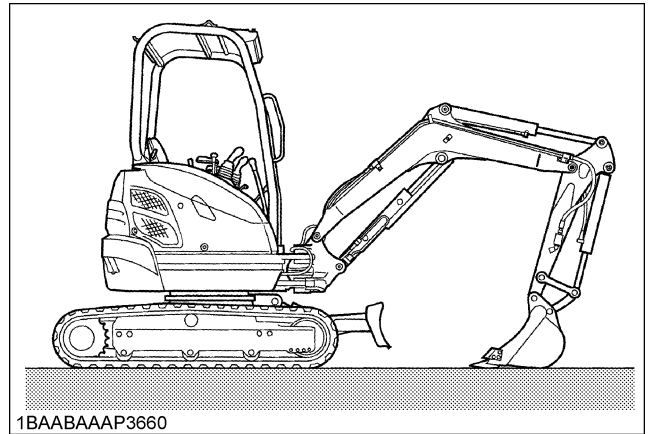

1BAABAAAP3660

2. Check the oil level as to whether it lies on the center of the gauge at normal temperature (10 to 30 °C (50 to 80°F)).

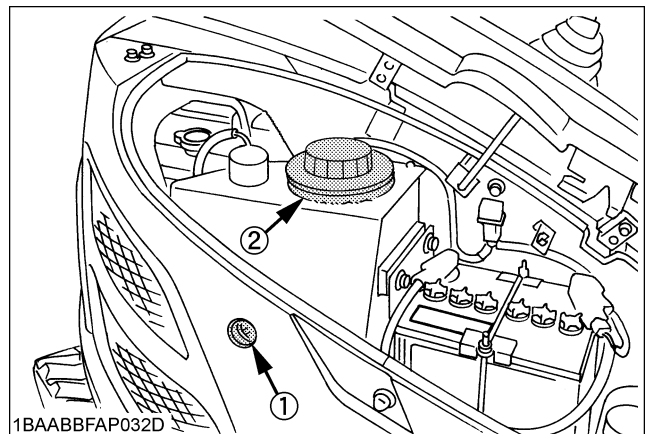

1BAABBFAP032D

(1) Specified oil level (2) Tank cap

■Checking Coolant Level

CAUTION

To avoid personal injury:

- Move the excavator to even ground.
- Make sure that the engine is turned off.
- Do not open the radiator cap right after the engine has been stopped; Serious burns can occur from contact with escaping hot coolant fluid.
- Check the coolant level in the reserve tank only after the engine has cooled down.
- Remove the radiator cap only if absolutely necessary.

The radiator has a reserve tank. Should the coolant level in the radiator sink, the water will be automatically be transferred to the radiator.

Check the coolant level in the reserve tank and fill up if necessary. The coolant level should be between the marks "FULL" and "LOW".

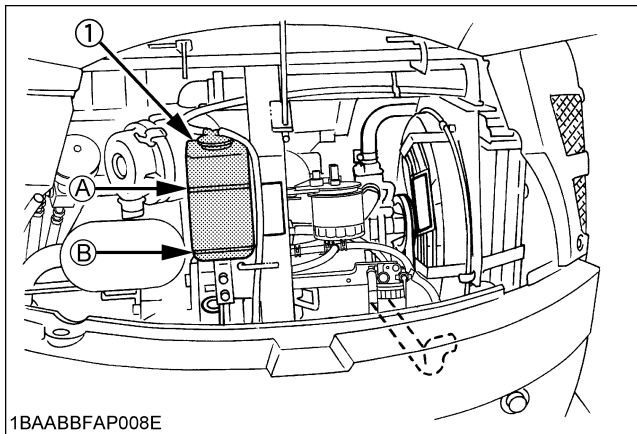

1BAABBFAP008E

(1) Reserve tank

(A) "FULL"
(B) "LOW"

IMPORTANT :

- Do not fill the reserve tank over the "FULL" marking.
- Do not fill with dirty or salty water.

■Lubrication Points

CAUTION

To avoid personal injury:

- First lower all attachments on the ground then stop the engine and remove the key.
- While greasing, take care not to step on the bucket teeth.
- When doing excavation work in water, generously grease the following points. After ending work, grease again.

Grease the marked grease nipples shown by arrows in the illustration below.

- | | | |
|-----|--|----------|
| 1. | Boom bottom linkage..... | 1 place |
| 2. | Arm bottom linkage..... | 1 place |
| 3. | Bucket link pin..... | 3 places |
| 4. | Boom cylinder pin..... | 1 place |
| 5. | Boom cylinder boss..... | 1 place |
| 6. | Arm cylinder boss..... | 1 place |
| 7. | Arm cylinder pin..... | 1 place |
| 8. | Bucket cylinder pin..... | 1 place |
| 9. | Fixing pin between arm and bucket..... | 1 place |
| 10. | Boom swing fulcrum..... | 2 places |
| 11. | Swing cylinder boss..... | 2 places |
| 12. | Dozer cylinder boss..... | 2 places |
| 13. | Dozer linkage pin..... | 2 places |

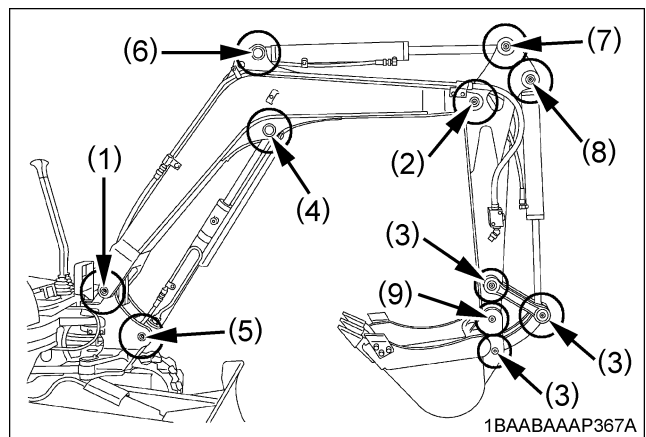

1BAABAAAP367A

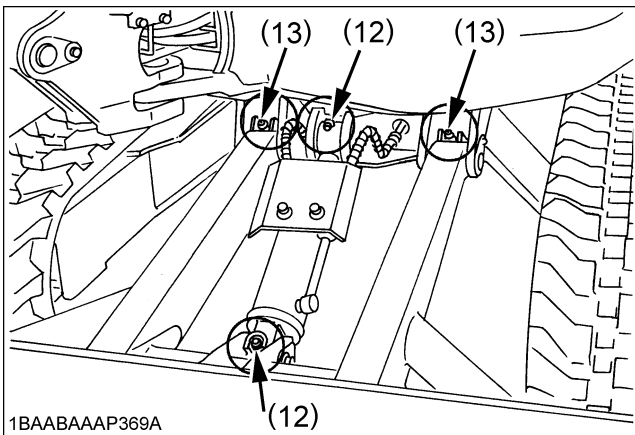
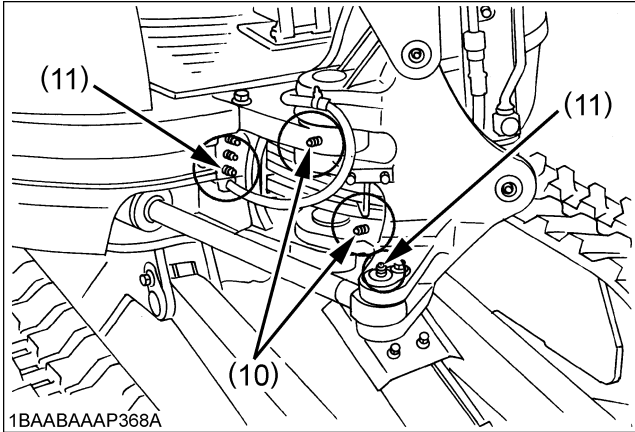

■ Check Fan Belt



CAUTION

To avoid personal injury:

- Stop the engine and remove the key before checking the fan belt.
- Check the fan belt for cracks and proper tension. (See "Checking Fan Belt Tension" in "REGULAR CHECKS AND MAINTENANCE WORK" section.)

■ Check Radiator and Oil cooler



CAUTION

To avoid personal injury:

- Always stop the engine and remove the key before checking the radiator.
- Wear eye protection when cleaning with compressed air.

1. Check if the fins and ribs are clogged. If so, clean with compressed air or steam.
2. Check the rubber hoses for damage and replace if cracked or old. Check if the hose clamps are tight enough.

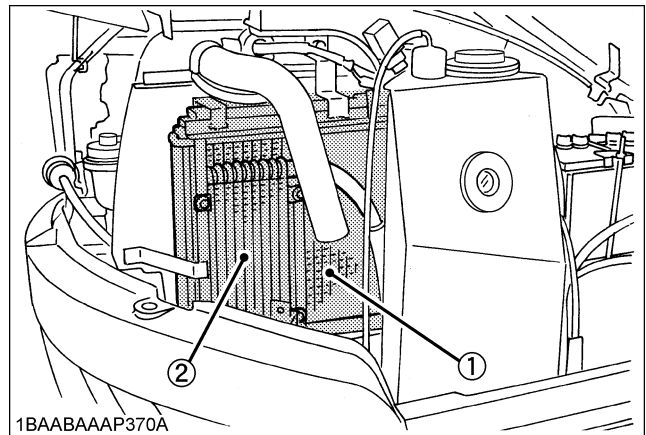

- (1) Radiator
- (2) Oil cooler

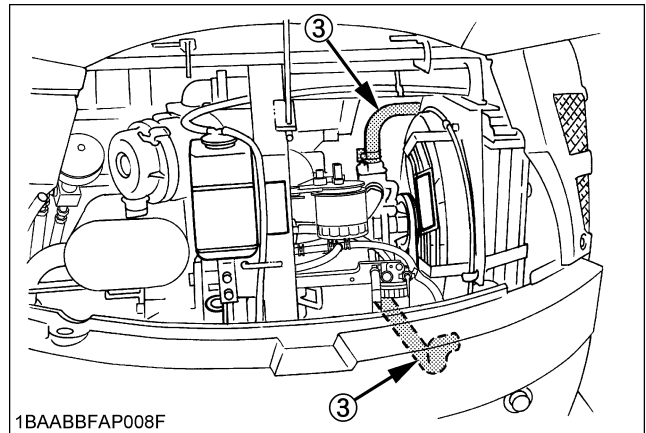

- (3) Rubber hoses and clamps

IMPORTANT :

- Radiator fins and ribs must be clean in order not to overheat the engine and allow free flow of air through the cooling elements.

■ Cleaning of Engine and Electrical Wiring



CAUTION

To avoid personal injury:

- Always stop the engine and remove the key before cleaning the wiring, cables and engine.

Before starting, check whether flammable substances have gathered on the battery, the cables and wiring, the muffler or on the engine. If so, remove thoroughly.

■ Washing Whole Machine

IMPORTANT :

- Do not wash the excavator with the engine running.
Water could enter the air filter and damage the engine.
Make sure that the air filter is kept dry.
- Remove the mud before washing the machine.

REGULAR CHECKS AND MAINTENANCE WORK

EVERY 50 SERVICE HOURS

■ Draining Fuel Tank



CAUTION

To avoid personal injury:

- Before draining the fuel tank, be sure to stop the engine and remove the key.
- Do not smoke during inspection.

1. Remove the drain plug on the underside of the body and drain water.
2. Re-tighten the drain plug.

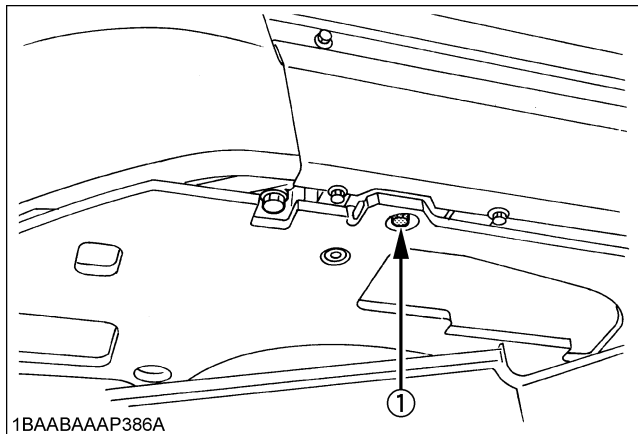

(1) Drain plug

■ Draining Water Separator

1. Open the hood.
2. When the separated water is being drained, the red float moves upwards. When the float reaches the line, close the cock so that no fuel can run out. Now loosen the ring nut, and remove the cup and empty completely.
3. Finally, do not forget to open the cock and close the hood.

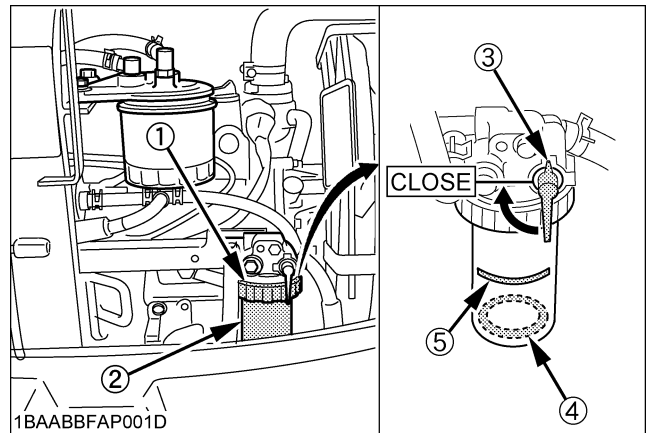

- (1) Ring nut
(2) Cup
(3) Cock

- (4) Float
(5) Line

■ Battery



DANGER

To avoid the possibility of a battery explosion: For refillable type battery, follow the instructions below.

- Do not use or charge the refillable type battery if the fluid level is below the LOWER (lower limit level) mark. Otherwise, the battery component parts may prematurely deteriorate, which may shorten the battery's service life or cause an explosion. Check the fluid level regularly and add distilled water as required so that the fluid level is between the UPPER and LOWER levels.



CAUTION

To avoid personal injury:

- Batteries contain sulphuric acid which can cause severe burns. Avoid all contact with skin, eyes or clothing. Antidote - External: Rinse with plenty of water. Internal: Drink large quantities of water or milk. Follow with milk of magnesia, beaten egg or vegetable oil. Call a physician immediately. Eyes: Rinse with plenty of water for 15 minutes and get prompt medical attention. Keep batteries out of the reach of children.
- Before inspection or dismantling the battery, be sure to turn the starter switch to the "OFF" position and turn off the engine.
- When removing the battery, always disconnect the negative ground cable first. The reverse when installing a battery, always connect the ground cable last. This prevents a possible explosion caused by sparks.
- Always wear eye protection when working with the battery.

1. Check the battery fluid level and add distilled water if necessary.
2. Clean the battery caps (ventilation holes).

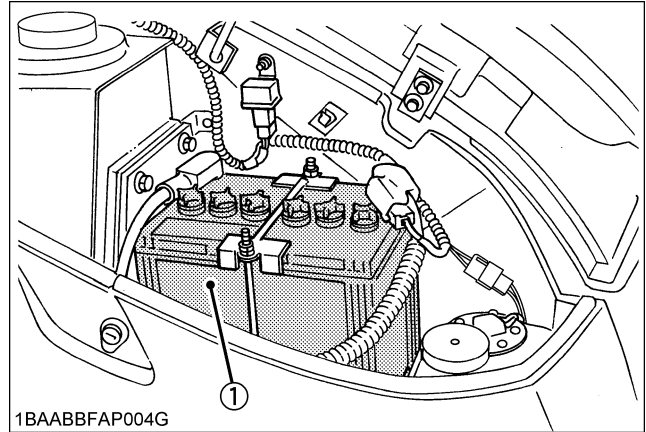

(1) Battery

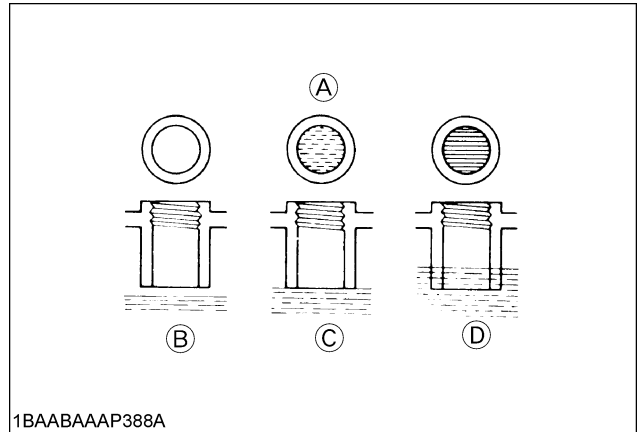

- (A) Battery fluid level
 (B) "Too low"
 (C) "Correct"
 (D) "Too high"

■ Battery Charging



CAUTION

To avoid personal injury:

- When the battery is being activated, hydrogen and oxygen gases in the battery are extremely explosive. Keep open sparks and flames away from the battery at all times, especially when charging the battery.
- When charging battery, remove battery vent plugs.
- When disconnecting the cable from the battery, start with the negative terminal first. When connecting the cable to the battery, start with the positive terminal first.
- Do not check battery charge by placing a metal object across the terminals. Use a voltmeter or hydrometer.

1. Make sure each electrolyte level is to the bottom of vent wells, if necessary add distilled water in a well-ventilated area.
2. The water in the electrolyte evaporates during recharging. Liquid shortage damages the battery. Excessive liquid spills over and damages the excavator body.
3. To slow charge the battery, connect the battery positive terminal to the charge positive terminal and the negative to the negative, then recharge in the standard fashion.
4. A boost charge is only for emergencies. It will partially charge the battery at a high rate and in a short time. When using a boost-charged battery, it is necessary to recharge the battery as early as possible. Failure to do this will shorten the battery's service life.
5. When the specific gravity of electrolyte falls between 1.27 and 1.29 charge has completed.
6. When exchanging an old battery for a new one, use a battery of equal specification.

■ Greasing of Swing Bearing Teeth

1. Pump grease with grease gun through the grease nipple.
2. Grease at each 90° (1.58 rad.) position of the swing frame.
3. Fill with approx. 50g of grease (approx. 20 pumps with the grease gun). Distribute the grease over the teeth.

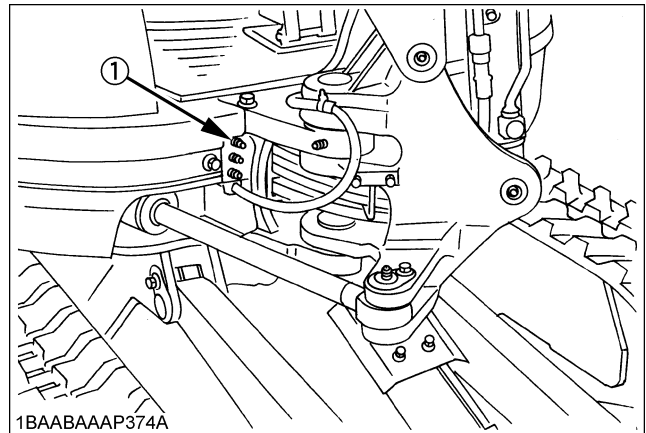

(1) Grease nipple (for Bearing teeth)

EVERY 200 SERVICE HOURS

Do all 50 hour servicing at the same time.

■ Checking Fan Belt Tension**◆ Check and adjustment of the fan belt tension****CAUTION**

To avoid personal injury:

- First stop the engine and remove the key.
- After servicing, make sure to replace the belt cover in its original position.

1. Press the fan belt down in the middle, with a force of approx. 68.6 N (7 kgf). The belt tension is correct if it deflects about 7 mm. If otherwise, loosen bolt (1) and (2) and shift the alternator (3) in the direction shown by the arrow.
2. Replace the fan belt if worn out, cracked or torn.

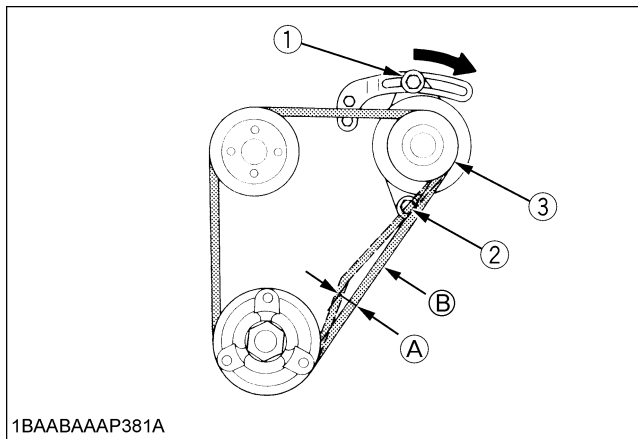

1BAABAAP381A

- | | |
|----------------|-------------------|
| (1) Bolt | (A) about 7 mm |
| (2) Bolt | (B) approx. 7 kgf |
| (3) Alternator | |

IMPORTANT :

- If the engine is run with a loose fan belt, the belt could slip and cause overheating of the engine or insufficient battery charging. Check fan belt tension regularly.
- Should the fan belt break or jump off, the indicator light for battery charge will light up. Stop the engine and remove the key immediately.

■ Checking Radiator Hoses and Clamps**CAUTION**

To avoid personal injury:

- Wait long enough for the radiator coolant to cool down.

Check the water hoses for proper connection. This check should be carried out every 200 hours or every 6 months, whichever comes first.

1. Should the hose clamps become loose or water leaks, tighten the hose clamps properly.
2. Should the radiator hoses become swollen, aged or cracked, they must be replaced and the hose clamps tightened again properly.

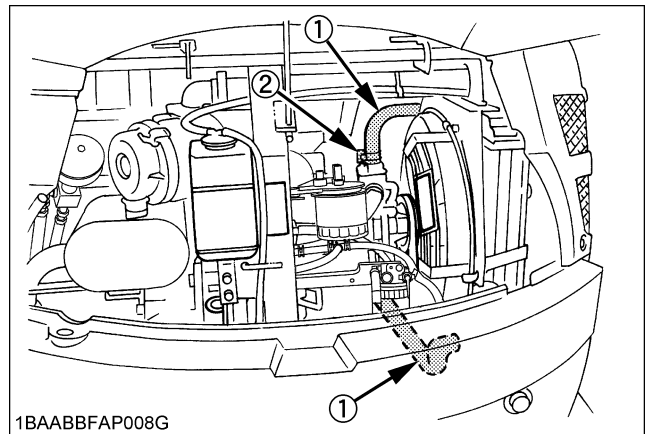

1BAABBFAP008G

(1) Radiator hoses

(2) Hose clamps

■ Inspection and Cleaning Air Filter Element

Open the engine bonnet and remove the dust-cover. Take out only outer element, clean the element, case interior and reassemble. During reassembly, take care to install the dust-cover so that its TOP mark (arrow) faces upwards. Do not remove the inner element.

IMPORTANT :

- Should the machine be used in extremely dusty areas, the air filter element must be inspected and cleaned more frequently than in the specified maintenance periods.
- The air filter has a dry element, keep free from oil.
- Do not run the engine without the air filter.

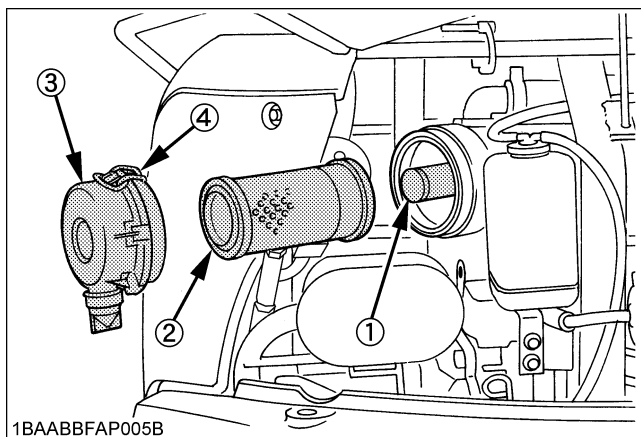

- (1) Inner element
- (2) Outer element
- (3) Dust-cover
- (4) Clamps

■ Air Filter Maintenance



CAUTION

- To avoid personal injury:
- Wear eye protection.

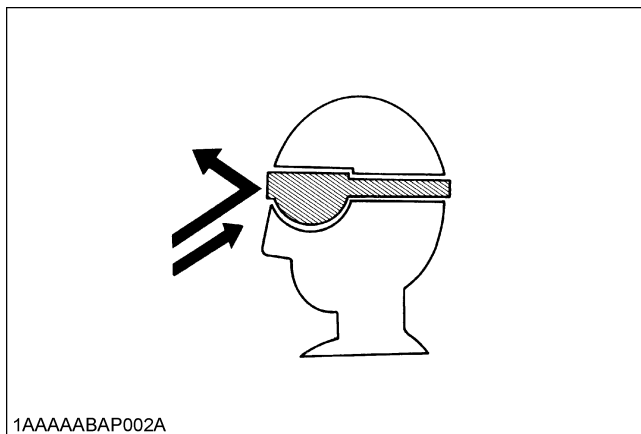

1AAAAABAP002A

◆ Cleaning with compressed air

Pressure of compressed air must be under 205 kPa (2.1 kg/cm²), and the cartridge should be blown clean from the inside to the outside until the dust deposits are remarkably reduced.

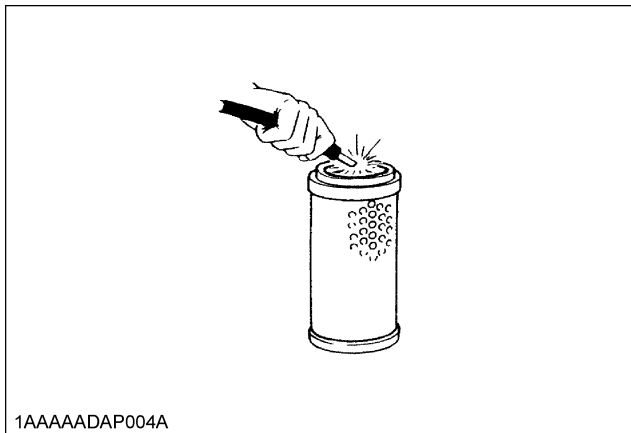

1AAAAADAP004A

IMPORTANT :

- If the air suction is still inadequate, or the colour of the exhaust gases is abnormal even after the cleaning, the air filter element must be replaced.

■ Greasing Swing Bearing

1. Grease through the respective grease nipple. (at the central nipple)
2. Grease at each 90° (1.58 rad.) position of the swing frame.

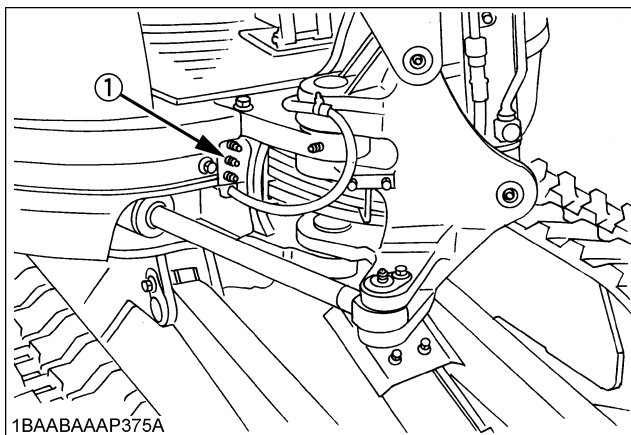

1BAABAAAP375A

- (1) Grease nipple

■Checking Fuel Line and Intake Air Line

1. Check to see that all lines and hose clamps are tightened and not damaged.
2. If hoses and clamps are found worn or damaged, replace or repair them at once.

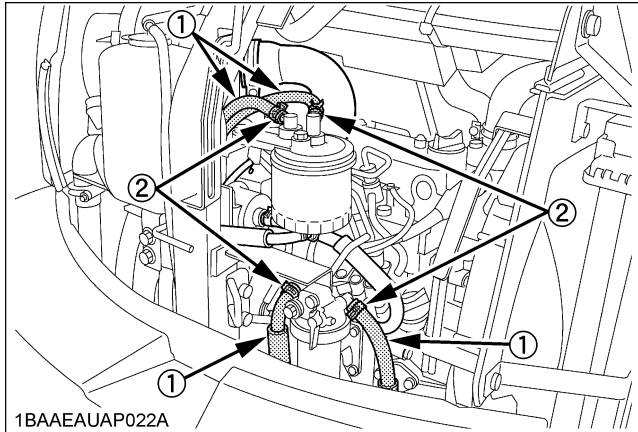

- (1) Fuel lines
- (2) Clamp bands

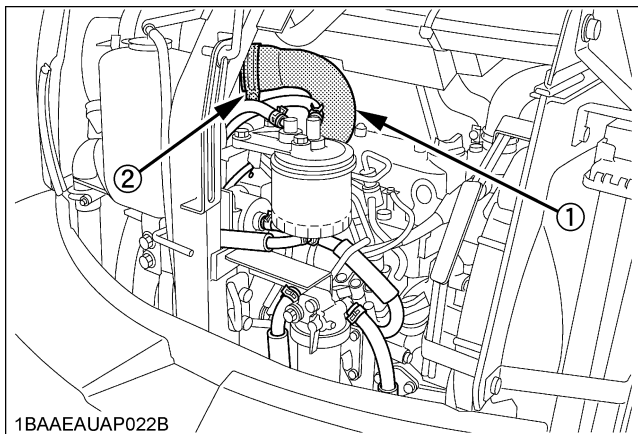

- (1) Hoses
- (2) Hose clamps

EVERY 250 SERVICE HOURS

Do all 50 hour servicing at the same time.

■Engine Oil Change (First Engine Oil Change after 50 Service Hours)



CAUTION

To avoid personal injury:

- First stop the engine then remove the key and wait long enough for the oil to cool down.

1. Remove the drain plug on the underside of the engine and drain all oil.
2. Re-tighten the drain plug.

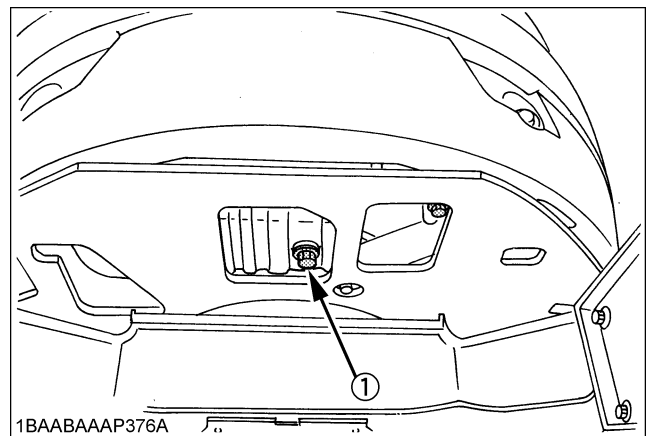

- (1) Drain plug

3. Fill with new oil up to the required level.

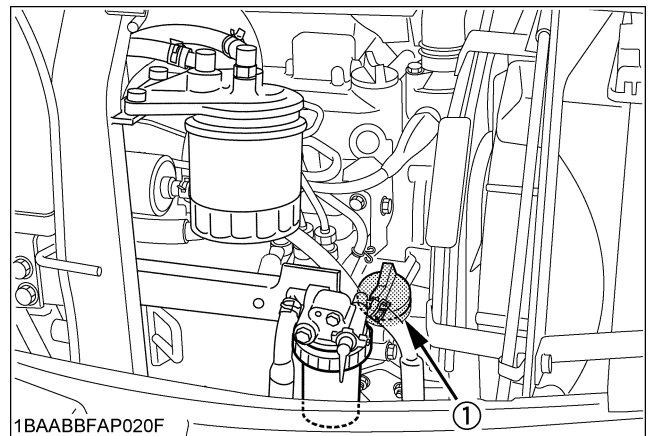

- (1) Oil filling port

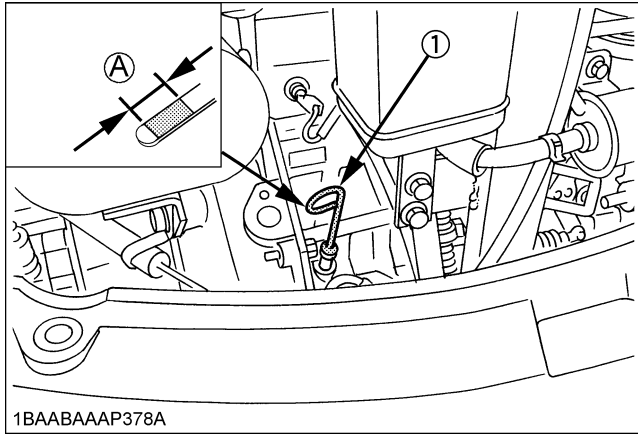

(1) Engine oil dipstick (A) Required level

4. Let the engine idle for approx. 5 min. Check the engine oil level. To check the engine oil level, insert the engine oil dipstick completely into the respective port opening and pull out again. If the oil level lies between both markings, no oil must be added.

IMPORTANT :

- Regardless of the service hours, an engine oil change is due every six months.

Engine oil volumes (with engine oil filter)	4.4 L
--	-------

■ Replacing Engine Oil Filter (First Engine Oil Filter Change after 50 Service Hours)

1. Replace the oil filter cartridge at the same time as doing engine oil change.
2. Remove the cartridge with the supplied filter wrench.

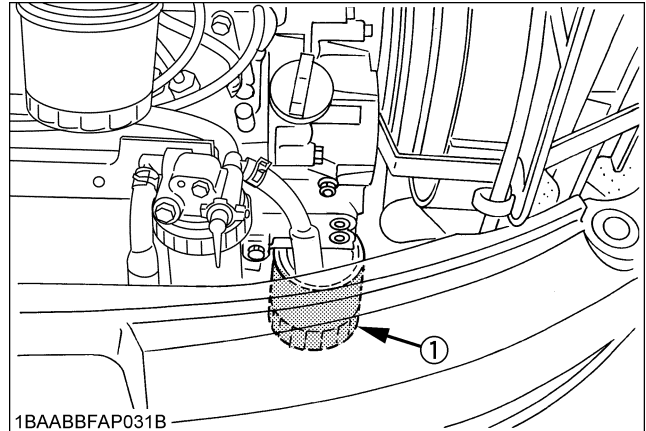

(1) Oil filter cartridge

3. Oil the O-ring of the new oil filter cartridge lightly. Then tighten the oil filter cartridge by hand.
4. Fill engine oil to the specified level.
5. Let the engine run for approx. 5 min. and make sure that the engine oil indicator lamp does not light up. Then stop the engine and remove the key.
6. The engine oil level will sink parallel to the oil filter capacity after the engine is started. It is necessary to add oil.

IMPORTANT :

- Always check the oil level when replacing the filter.

■ Lubrication of the Pilot Valve

Remove the rubber bellows from the underside of the control levers. Grease the tip of the push rod and the rotating part of the link.

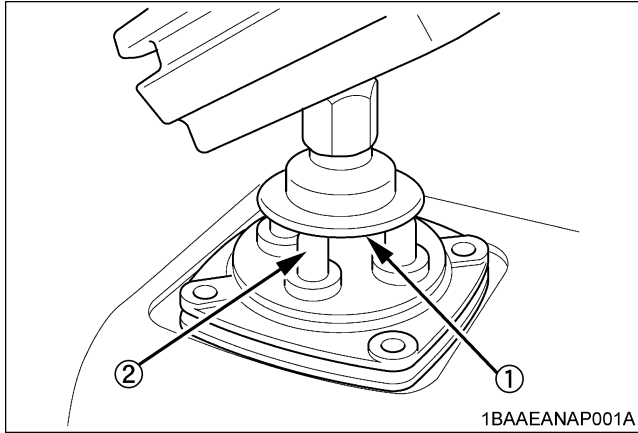

(1) Rotating part of the link
(2) Tip of the push rod

EVERY 500 SERVICE HOURS

Do all 50 and 250 hour servicing at the same time.

■ Drive unit Oil Change (First Oil Change at 100 hours)



CAUTION

To avoid personal injury:

- Lower to the ground, stop the engine and remove the key before undertaking the oil change.

1. Rotate the track so that the drain plug of the drive unit is in the bottom position.
2. Remove the drain plug to let the oil run out. Screw in and tighten the drain plug again and fill with gear oil through the oil check port.
3. Fill oil until it overflows out of the oil check port.

Gear oil volumes	approx. 0.35 L
------------------	----------------

Oil change

- first oil change after 100 hrs
- then every 500 hrs
- or at least once a year

4. Use prescribed gear oil SAE 90.

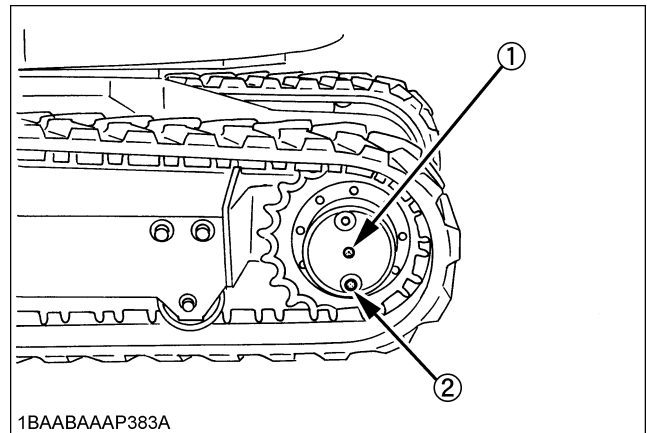

(1) Oil check port (also serves as oil filling port)
(2) Drain plug

■ Replacing Fuel Filter Cartridge



CAUTION

To avoid personal injury:

- Keep fire away.

1. Remove the filter with the supplied filter wrench.
2. Add fuel to a new filter before installing.
3. Apply a light film of fuel to the seal of the new filter and turn in tightly by hand.
4. Open the cock of the fuel filter again.

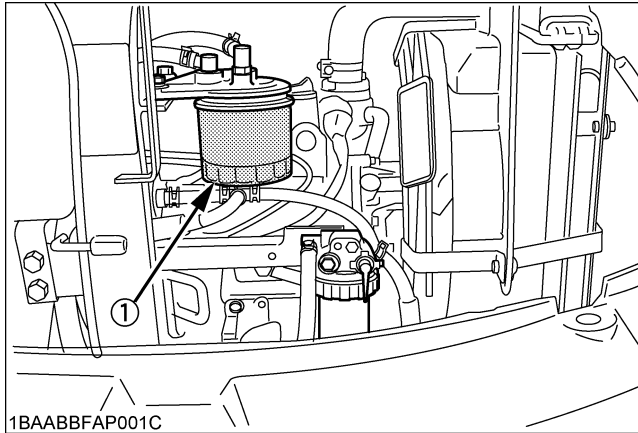

(1) Fuel filter cartridge

IMPORTANT :

- After exchange of the filter, the fuel system must be purged of air.

■ Replacing Hydraulic Return Filter Element (first replacement after 250 service hours)



CAUTION

To avoid personal injury:

- Remove the oil filter only after the oil in the hydraulic tank has cooled down.

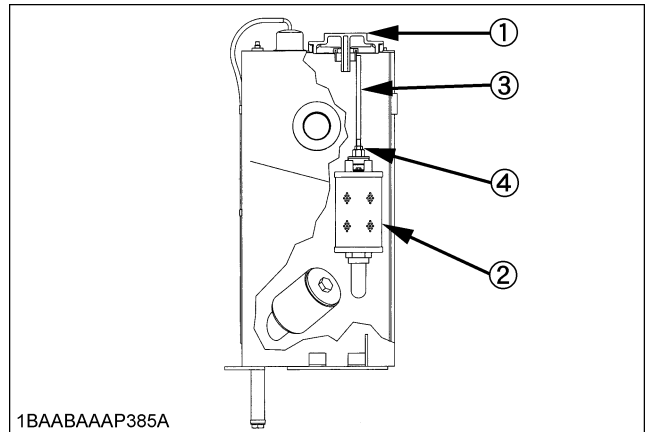

- (1) Cover
- (2) Return filter
- (3) Filter support
- (4) Lock nut

1. Remove the cover of the hydraulic tank.
2. Pull out the filter support by the top from the hydraulic tank.
3. First loosen the lock nut, then remove the return filter from the filter support and replace with a new filter. Do not forget to tighten the lock nut.

IMPORTANT :

- Always check the oil level when replacing the filter.

EVERY 1000 SERVICE HOURS

Do all 50, 200, 250 and 500 hour servicing at the same time.

■ Cleaning of the Pipe filter of the Hydraulic Pilot System (for Hydraulic Pilot Types)

Dust and dirt collect on the concave side of the filter. Clean the filter by letting hydraulic oil flow through from the convex side.

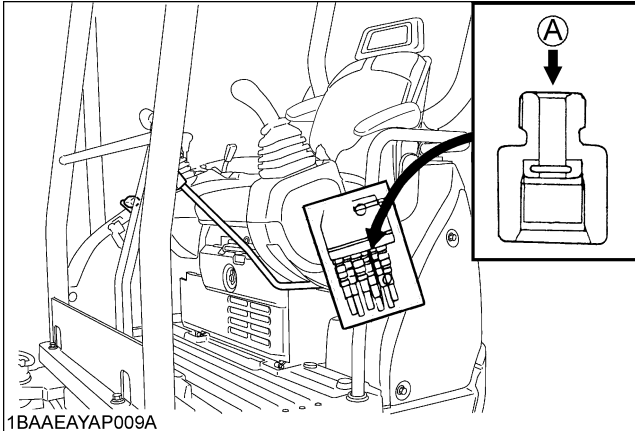

(A) Oil

■ Replacing the Hydraulic Pilot Filter Element



CAUTION

To avoid personal injury:

- Before replacing the element, wait long enough for the hydraulic fluid to cool down.

1. Remove the arch cover.
2. Remove the hydraulic oil tank cover.
3. Remove the pilot filter case from the head cover.
4. Wrench and pull out the element downward.
5. Replace the O-ring with a new one.
6. Apply a light coating of clean hydraulic oil to the O-ring and fit it to the case firmly. Be careful not to scratch the O-ring.
7. Fit the case to the head cover.
8. Let the engine run for approx. 3 minutes.
9. Check the oil level of hydraulic oil tank.

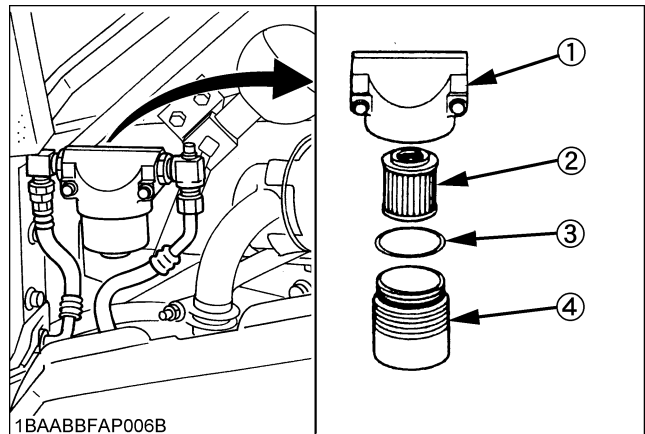

- (1) Head cover
- (2) Element
- (3) O-ring
- (4) Case

Hydraulic Oil Change (Including Replacing of the Suction Filter in the Hydraulic Tank)

CAUTION

To avoid personal injury:

- Wait long enough for the hydraulic fluid to cool down. Then begin with the change of the hydraulic fluid.

1. Move the excavator to a level ground and stop the engine. Extend the piston rods of the cylinders halfway out and lower the bucket on the ground.

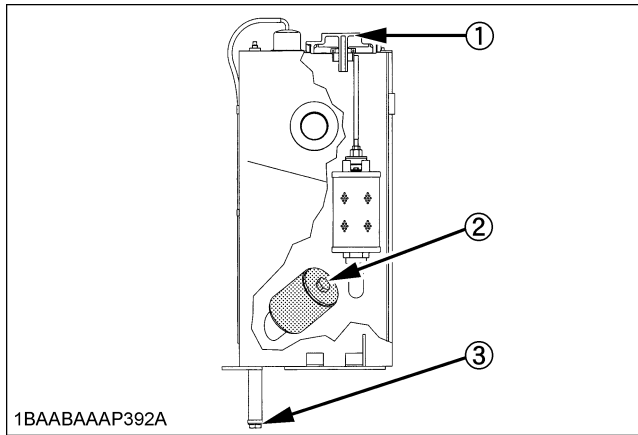
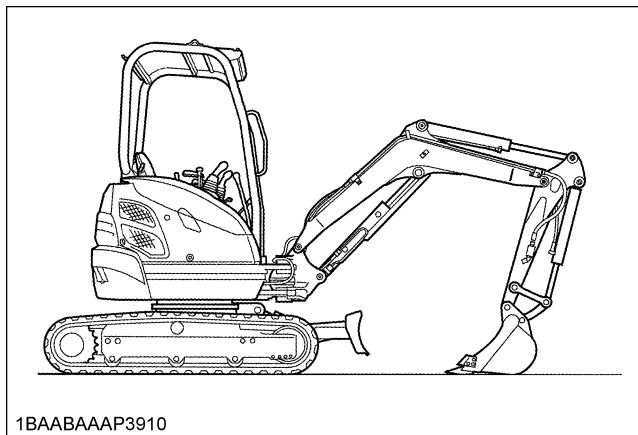

- (1) Cover
- (2) Suction filter
- (3) Drain plug

2. Remove the drain plug on the underside of the hydraulic tank and drain the oil.

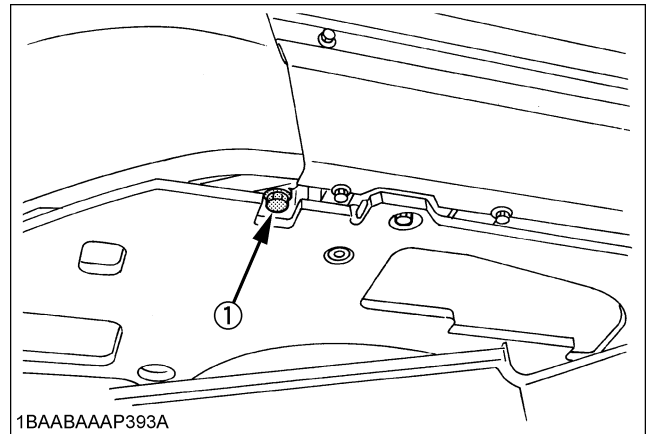

- (1) Drain plug
3. Remove the cover of the hydraulic tank.
4. With a fork wrench or similar, remove and exchange the suction filter.
5. Retighten the drain plug.
6. Fill oil through the oil filling opening on the top side of the tank.
7. Let the engine run for approx. 5 min. and check the oil level again.

Hydraulic oil volumes	Hydraulic tank	22.5 L
	Whole oil volumes	37 L

■Hydraulic Oil Check with Hydraulic Breakers

The hydraulic oil change after 1000 operating hours in the operator's manual is based on normal excavator work. Following inspection measures are valid when hydraulic breakers are used:

1. Changing and filling up of hydraulic oil
 - (1) The hydraulic oil must be changed more often when breakers are used because the machine is subject to harder conditions than at normal excavating work.
 - (2) Use only the recommended oils mentioned in the operator's manual when changing or fill oil.
 - (3) When filling up oil, do not mix oils of different makes.
2. Changing the return filter and oil
 - (1) The filter must be changed more often because of contamination resulting from the frequent assembly and disassembly of the hoses.
 - (2) Use the correct replacement filter.
 - (3) Oil change according to operating hours.

		Hydraulic oil	Return filter
Normal excavator work		every 1000 Hrs.	every 500 Hrs. (250 Hrs. after first operation)
Breaker work portion	20%	every 800 Hrs.	every 200 Hrs.
	40%	every 400 Hrs.	
	60%	every 300 Hrs.	every 100 Hrs.
	more	every 200 Hrs.	

EVERY 1000 SERVICE HOURS OR ONCE A YEAR

■Replacing Air Filter Element

Open the engine bonnet and remove the dust-cover. Remove and replace the outer element and inner element with new elements.

When reassembling, install the dust-cover so that its TOP mark (arrow) faces up-wards.

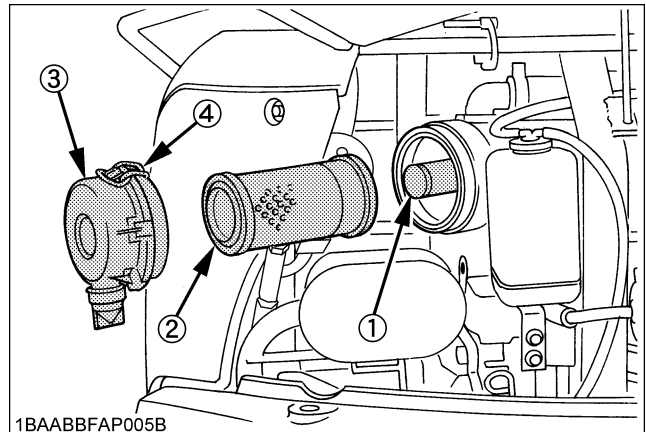

- (1) Inner element
- (2) Outer element
- (3) Dust-cover
- (4) Clamps

IMPORTANT :

- Shorten the replacement period if the machine is used in dusty or sandy areas.

EVERY 1500 SERVICE HOURS

■Checking Fuel Injection Nozzle(Injection Pressure)

Consult your local KUBOTA Dealer for this service.

EVERY 2000 SERVICE HOURS

Do all 50, 200, 250, 500 and 1000 hour servicing at the same time.

■Changing Front Idler and Track Roller Oil

NOTE :

- Contact your KUBOTA dealer for details.

■Checking the Alternator and Starter Motor

NOTE :

- Contact your KUBOTA dealer for details.

EVERY 3000 SERVICE HOURS

■Checking Injection Pump

Consult your local KUBOTA Dealer for this service.

ANNUAL SERVICING

■ Electrical Wiring and Fuses

Check the terminals periodically for proper connections. Loose wiring or damaged cables can cause improper functioning or short circuiting of the electrical system. Check wiring and replace damaged components immediately. If a fuse blows out soon after having been replaced, contact your nearest KUBOTA dealer. Never use a fuse other than specified.

■ Checking the Electrical Circuit

Check the electrical circuitry for disconnections, shorts or loose terminals.

BIENNIAL SERVICING



CAUTION

To avoid personal injury:

- Do not loosen the radiator cap before the radiator has cooled down sufficiently. Then only loosen the cap and allow enough time for the pressure in the system to be released. Now remove the cap completely.

■ Replacement of Radiator Hoses

Replace radiator hoses and hose clamps every two years. If the hoses are swollen, hard or cracked, they must be replaced earlier.

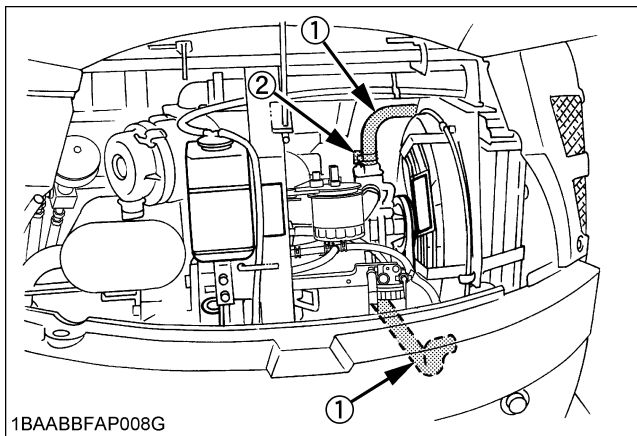

1BAABBFAP008G

- (1) Radiator hoses
(2) Hose clamps

■ Changing Radiator Coolant

(In case of long-life coolant fluid)

Stop the engine then remove the key and wait until it has cooled down completely.

1. Open the drain plug or cock on the bottom of the radiator and drain coolant completely.
2. To clean, rinse the radiator with water.
3. Close the drain plug or cock and fill the radiator and the reserve tank with coolant fluid. Let the engine idle for about 5 min., stop the engine and check the coolant level then remove the key.
4. The machine has been shipped filled with 50% anti-freeze solution.

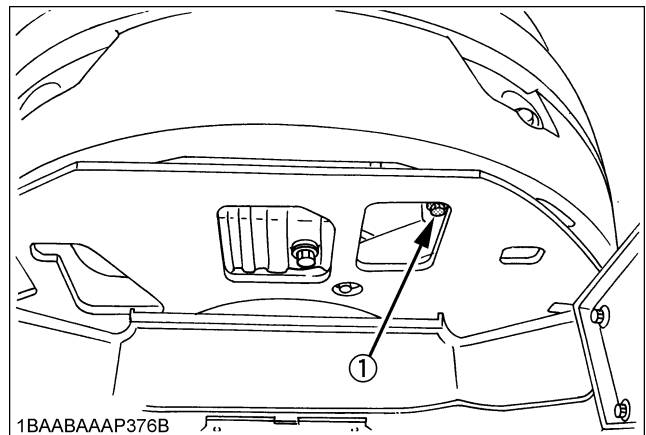

1BAABAAAP376B

- (1) Drain plug

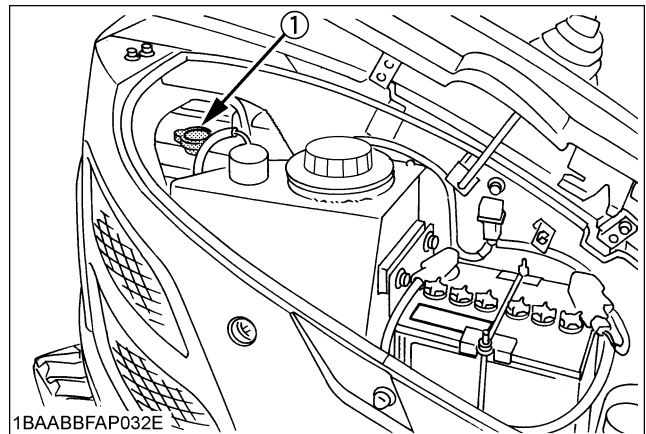

1BAABBFAP032E

- (1) Radiator cap

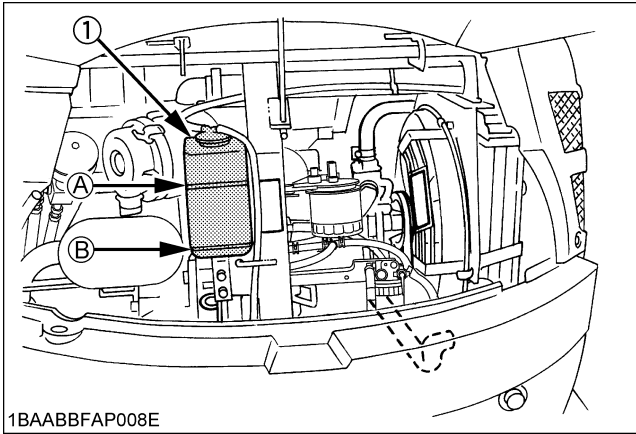

1BAABBFAP008E

- (1) Reserve tank
 (A) "FULL"
 (B) "LOW"

Radiator	2.4 L
Reserve tank	0.6 L

IMPORTANT :

- Do not operate the engine without coolant.
- To fill the radiator system use fresh water and anti-freeze fluid.
- When the anti-freeze is mixed with water, the anti-freeze mixing ratio must be less than 50%.
- Tighten the radiator cap properly. If the cap is loosely or not properly fitted, overheating of the engine can result due to coolant fluid loss.

■ Replacing Fuel Hose

Replace the hoses and clamps.
 (See "Checking Fuel and Intake Air Line" every 200 hours maintenance.)

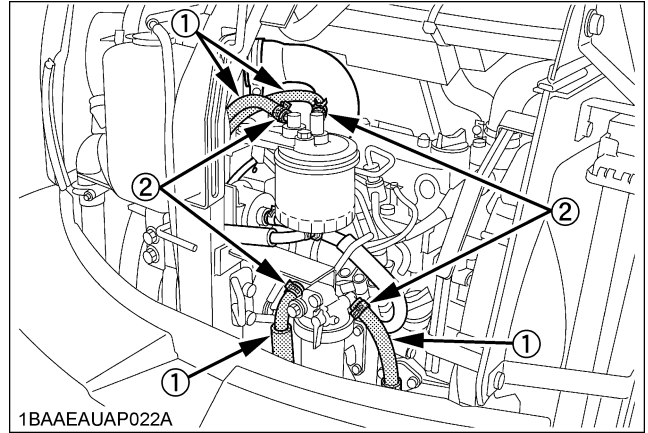

1BAAEUAP022A

- (1) Fuel lines
 (2) Clamp bands

■ Replacing Intake Air line

Replace the hoses and clamps, if necessary.
 (See "Checking Fuel and Intake Air Line" every 200 hours maintenance.)

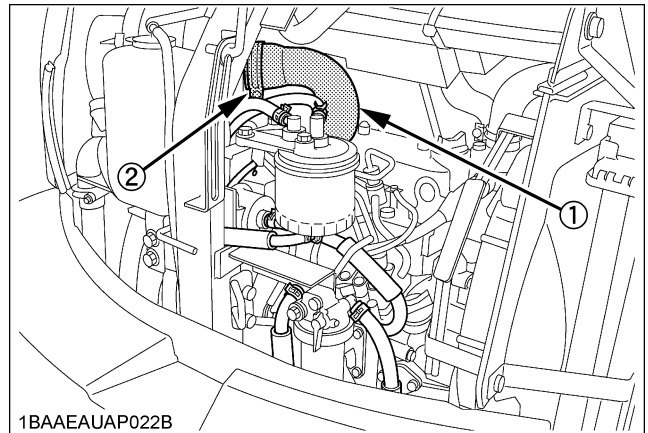

1BAAEUAP022B

- (1) Hoses
 (2) Hose clamps

OTHER ADJUSTMENTS AND REPLACEMENTS

PURGING OF THE FUEL SYSTEM

1. Fill up the excavator with fuel.
2. Turn the starter key to the position "RUN" (●).
3. The air in the fuel system will automatically be purged within one minute.

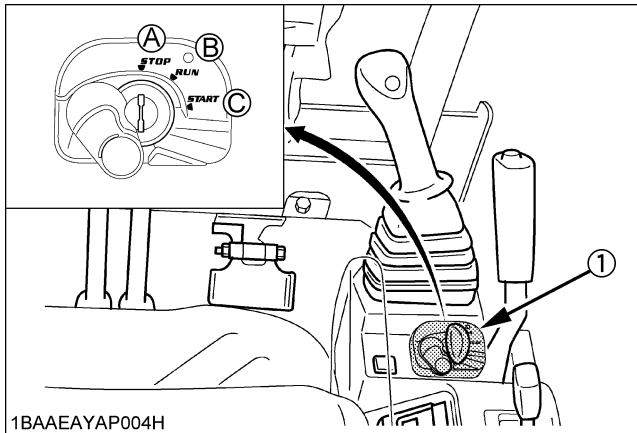

1BAAEAYAP004H

(1) Starter switch

(A) "STOP"
 (B) "RUN"
 (C) "START"

IMPORTANT :

- If the purging was insufficient, the engine dies right after starting. In this case repeat steps 2 to 3 again.

ADJUSTMENT OF TRACKS

- ◆ To loosen the tracks, follow the following procedure:



CAUTION

To avoid personal injury:

- Do not loosen the grease nipple completely or too quickly. Otherwise grease under high pressure in the tension cylinder could squirt out.
- Do not crawl under the excavator.

1. Using a socket wrench, loosen the grease nipple a few turns.
2. When grease oozes out from the thread, rotate the track and loosen the track in the lifted position (see illustration).

After adjustment is completed:

Using the socket wrench, tighten the grease nipple. Tightening torque must be between 98 to 108 N-m.

IMPORTANT :

- If the tracks are too tight, wear is increased.
- If the tracks are too loose, the track pads may collide with the sprocket and wear is increased. The track may dislocate or come off.
- Clean the track after every use.
- Should the track tension be high due to sticking mud, lift the track with the help of the boom, arm and bucket, idle the engine and remove mud from the track by rotating it.

◆ Tension the tracks as specified:

1. Apply grease (2) to the grease nipple (1).

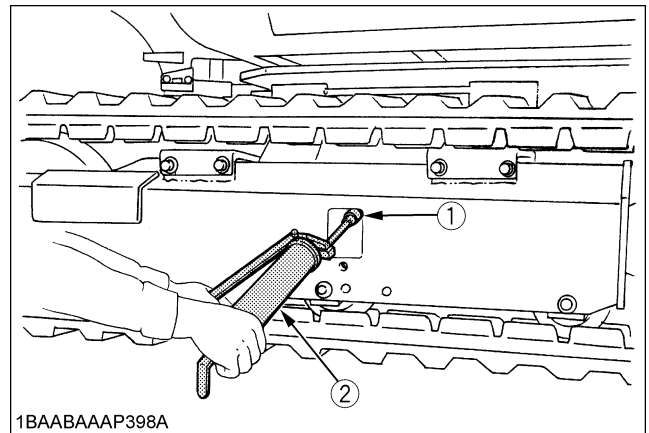

1BAABAAAP398A

- (1) Grease nipple
- (2) Grease gun

2. Rubber Tracks

Tension the track in the lifted position, so that the distance "A" (clearance between the track roller and the inside surface of the track) see illustration, in this case, the track seam is positioned on the top center between the idler and the sprocket.

Steel Tracks

To check the track tension, the track must be lifted from the ground as shown. The track tension is correct if the clearance between the outer end of the track roller and the track interior surface corresponds to the dimension specified in the table below.

**DANGER**

To avoid serious injury or death:

- Do not work under the machine in this condition.
- For your safety do not rely on hydraulically supported devices, they may leak down and suddenly drop or be accidentally lowered.

**WARNING**

To avoid personal injury or death:

- When lifting the machine itself with an attachment, place a safety block or safety post to prevent the machine from turning over. Keep the lock lever for attachment control in the "LOCK" position.

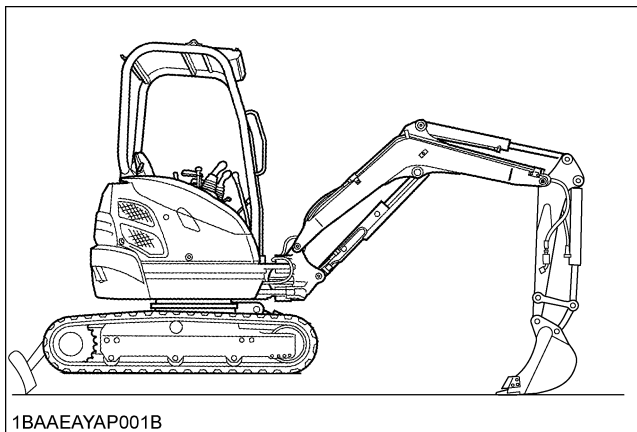
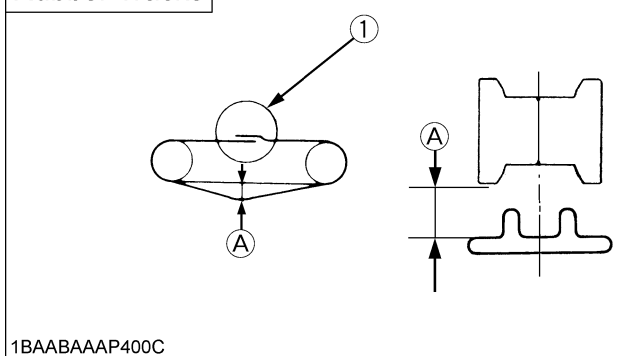
**Rubber Tracks**

(1) Seam (Mark "∞")

(A) 10 to 15 mm

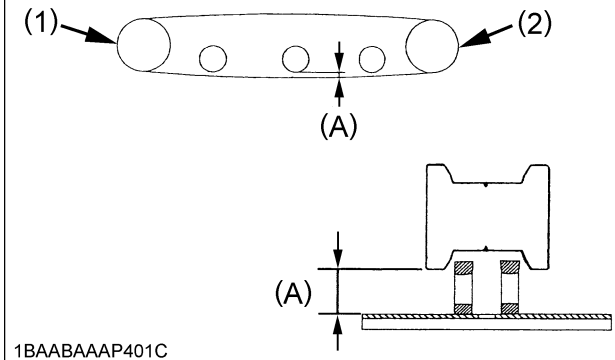
Steel Tracks

(1) Drive sprocket

(2) Idler

(A)

75 to 80 mm

IMPORTANT :

- Make sure that no obstacles, such as stones are caught in the track. Remove such obstacles before adjusting the track tension.

- Track seam

The ends of the rubber track are joined with a seam. When adjusting the tracks, the seam must be positioned on the top center between the idler and the sprocket.

If the seam is positioned incorrectly, the tracks will be tensioned too loosely, and a further readjustment will be necessary.

- Rotate the track after adjustment one to two times to check the tension.
- Additionally following points are to be observed when adjusting rubber tracks.

- (1) If the track loosen more than 25 mm, readjust them.
- (2) Check track tension 50 hours after initial use and readjust if necessary. Check and adjust thereafter every 50 service hours.

Special Information when Using Rubber Tracks

1. When turning, make a slow swing turn. Avoid spin turns to reduce lug wear and entry of dirt.
2. The relief valve may be activated if too much dirt and sand clog the tracks. In this case move the machine for a short distance straight backwards to let the earth and sand fall off, then a turn can be made.
3. Avoid using rubber track on riverbeds, stony underground, ferro-concrete and on iron plates. The rubber can damage as well as increase wear on the tracks.

CHANGING THE BUCKET



CAUTION

To avoid personal injury:

- When the coupling pins are removed or installed, chips may come off. Always use gloves, goggles and a helmet.
- When the change of the equipment must be performed with the engine running, always work as a 2-person team. One person sits in the operator's seat and the other works on the machine.
- Do not use your fingers to center the holes, since they may be injured or even cut in case of sudden or uncontrolled movements.
- Read the manual of the attachment to do a correct operation safely when other attachments are installed instead of Kubota specified bucket.

FUSES

■ Replacing Fuses

1. Remove the cover of the fuse box.
2. Replace the burnt out fuse with a fuse having the same capacity.

■ Fuse Capacities and Circuits

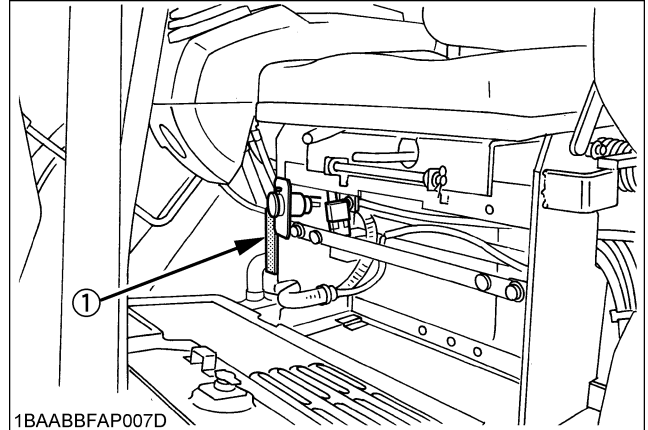

1BAABBFAP007D

(1) Fuse box

5A Room Light	
20A Work Light	
5A Meter Sub	
	10A Alternator Fuel Pump
	5A Lever Lock
	10A Horn
15A Cigarette Lighter	10A Meter Main
15A Auxiliary	5A Travel Hi-Low
15A Wiper / Washer	5A Relay Source

■ Slow Blow Fuse

Slow blow fuse is provided to protect the electrical circuits. If the fusible link is blown, check the electrical circuits for trouble and then replace with a new compatible slow blow fuse.

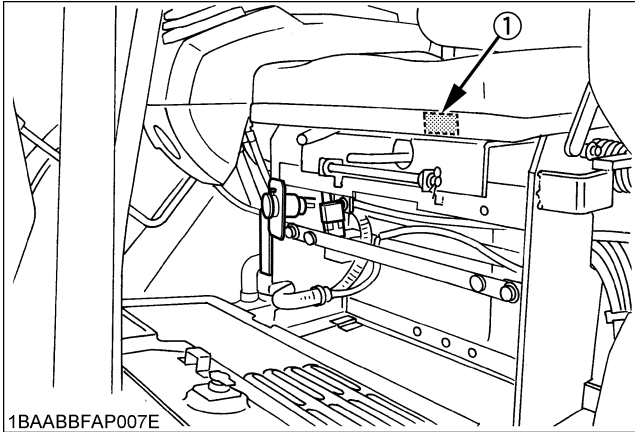

1BAABBFAP007E

(1) Slow blow fuse

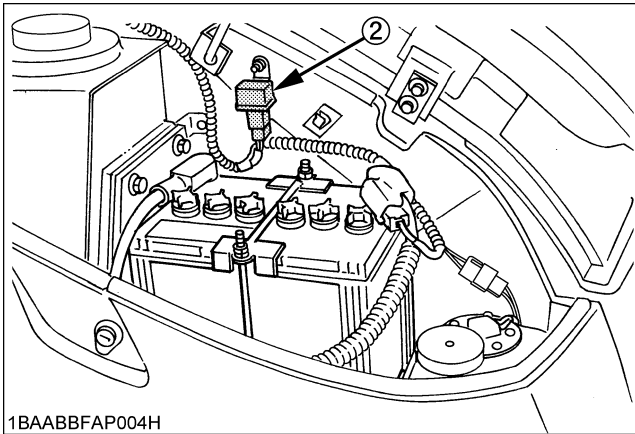

1BAABBFAP004H

(2) Slow blow fuse

Capacity of the slow blow fuse	(1)	60A
	(2)	50A

TROUBLESHOOTING

If the excavator does not show the desired performance, or when trouble arises, refer to the table below and undertake appropriate measures.

Trouble		Cause	Countermeasure
Engine	Starting difficulties	Fuel is too viscous	*Check fuel tank and filter *Remove impurities and water *If necessary, replace filter
		Air or water in the fuel system	*Remove water from the fuel tank *Check fuel pipe joint bolts and nuts for looseness *Purging of the fuel system (for fuel filter and injection pump, see "PURGING OF THE FUEL SYSTEM" in "OTHER ADJUSTMENTS AND REPLACEMENTS".)
		Oil viscosity is too high the engine runs sluggishly in winter	*Pour hot water over the radiator *Use oils of different viscosities depending on the ambient temperature. (Use SAE10W, SAE10W-30 or SAE10W-40)
		Battery is almost dead; insufficient compression	*Recharge battery
	Insufficient engine power	Low fuel level	*Check fuel and add if necessary
		Clogged air cleaner	*Clean the air filter element
	Engine suddenly stops	Low fuel level	*Check fuel and add if necessary *Purge the fuel system
	Abnormal exhaust gas color	Poor fuel	*Use high quality fuel
		Too much engine oil	*Drain engine oil to prescribed oil level
	Water temperature too high (Overheating)	Worn or torn fan belt	*Adjust or replace
		Coolant level too low	*Fill to prescribed level
		Radiator grill or fins are clogged	*Clean
		Coolant is contaminated with rust from the cylinder head or crank case	*Replace coolant fluid and add anti-rust
		Defective radiator cap (Evaporation)	*Replace
		Corroded coolant pipes	*Clean
		Continuous operation under full load	*Reduce load
		Engine oil level too low	*Fill to prescribed level
Use of poor fuel		*Use prescribed fuel	
Hydraulic System	Boom, arm, bucket, drive, swing and dozer power is too low	Hydraulic oil level too low	*Add oil
		Leakages of hoses and / or joints	*Replace hose or joint
	Swing motor and front attachment does not work	Lock lever in "LOCK" position	*Bring lock lever into "UNLOCK" position
Drive System	Deviation of drive direction	Blocked through stones	*Remove
		Track too loose or too tight	*Adjust accordingly
	Drive lever does not move	Lock lever in "LOCK" position	*Bring lock lever into "UNLOCK" position

KUBOTA I.C.S. NAVIGATION LIST OF MESSAGES

If an error occurs with the machine, one of the following messages appears in the LCD display.
In case of a trouble, immediately contact your local dealer for inspection and repair.

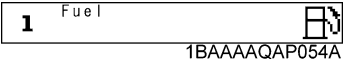
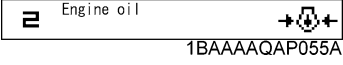
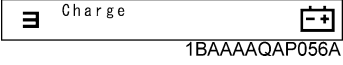
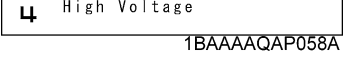
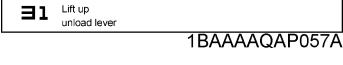
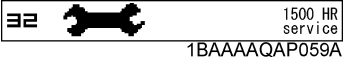
Message	Warning lamp Color	Problem or failure (what happened)	Machine behavior (provisional measure)	Correction
 <p>Fuel 1BAAAAQAP054A</p>	yellow	Fuel running out.	-	Add fuel.
 <p>Engine oil 1BAAAAQAP055A</p>	red	Engine oil circuit error (clogged) or engine oil shortage.	Immediately stop the engine.	The engine may be seized, failing to restart the engine. Immediately contact your local dealer for repair.
 <p>Charge 1BAAAAQAP056A</p>	red	Charging line in trouble. Charging failure.	Check the fan belt. (When the belt is in good condition, keep running until the battery becomes dead.)	Immediately contact your local dealer for repair.
 <p>High Voltage 1BAAAAQAP058A</p>	red	24V line engine startup alternator defective.	[Do not start the engine on 24V line. Get it restarted to see if there is the message again.]	If the message does not reappear, no repair is needed. If the message stays on, contact your local dealer for repair.
 <p>Lift up/unload lever 1BAAAAQAP057A</p>	yellow	The engine has been started with the lock lever down.	The engine fails to start.	Pull up the lock lever and start the engine.
 <p>1500 HR service 1BAAAAQAP059A</p>	yellow	The hour meter has reached the specified count-up. Carry out the maintenance job.	-	Carry out the specified maintenance job.
No message (warning lamp flashing)	red	Sensor power line short circuited.	The work light lights up.	Immediately contact your local dealer for repair.

◆ **Service hour meter**

When the hour meter has counted up to the hours circled in the maintenance list below, the message appears. The message shows up as follows.

No.	Check points		Intervals	Hour meter indicator								Consequently			
				50	100	250	300	550	600	750	800		1000		
1	Engine oil		change	●			○	○				○		every 250 hrs	
2	Hydraulic oil												○		every 1000 hrs
3	Air filter element	Outer element	replace										○	every 1000 hrs	
		Inner element											○	every 1000 hrs	
4	Drive unit oil		change		●					○				every 500 hrs	
5	Engine oil filter		replace	●			○	○				○		every 250 hrs	
6	Hydraulic return filter cartridge						●					○			every 500 hrs
7	Hydraulic suction filter element													○	every 1000 hrs

● First operation

The message appears. The message shows up as follows.

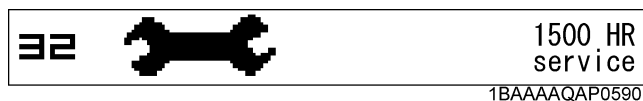

(The message reappears on the hour meter designated next.)

NOTE :

- The maintenance message disappears automatically in about 10 seconds.
 - When the key is turned from OFF to RUN, the maintenance message reappears and disappears again automatically in about 10 seconds.
 - When the key is turned from OFF to RUN repeatedly 10 times, the message disappears.
- ◆ In case the service hour meter replaced due to any trouble with it, the meter is set to "0". Contact your KUBOTA dealer for details.

OPERATION UNDER COLD WEATHER CONDITIONS

PREPARATION FOR OPERATION IN COLD WEATHER

1. Replace engine oil and hydraulic oil with those of viscosities suitable for cold weather.
2. In cold weather, battery power drops, and the battery fluid may freeze if the battery is not sufficiently charged. To prevent the battery fluid from freezing, be sure to keep the battery charged at least 75% or more of its capacity after operation. To ease next starting, it is recommended to keep the battery stored in closed or heated rooms. If the battery fluid level is too low, do not add after operation, but add with the engine running before the next operation.
3. Add anti-freeze to coolant in the radiator and reserve tank, if the ambient temperature is expected to drop below 0°C (32°F). Mixing ratio of water and anti-freeze depends on the expected ambient temperature.

- Mixing ratio between water and anti-freeze

Ambient Temperature	°C (°F)	-5 (+23)	-10 (+14)	-15 (+5)	-20 (-4)	-25 (-13)	-30 (-22)	-35 (-31)
Antifreeze %		30	30	30	35	40	45	50
Water %		70	70	70	65	60	55	50

IMPORTANT :

- Use permanent anti-freeze or long-life coolant.
- Drain the coolant completely and clean the inside of the radiator, then fill with the water and anti-freeze mixture.
- The anti-freeze acts as an anti-corrosive, it is not necessary to add an additive to the water and anti-freeze mixture.
- See "Coolant check" under "DAILY CHECKS" in "MAINTENANCE" for radiator fill volumes.

PROCEDURE AFTER DONE WORK

Clean the excavator thoroughly after work and wipe dry. Otherwise mud and earth on the tracks could freeze if the temperature drops below the 0°C (32°F) mark. Operation of the excavator is then not possible. Store the excavator in a dry place; if not possible, store on wooden planks or on mats. If the excavator is kept on damp or muddy ground, the tracks could freeze overnight. Operation of the excavator is then not possible. Furthermore the reduction gear may be damaged.

Additionally, the piston rods of the hydraulic cylinders must be rubbed dry. Otherwise severe damage could occur if dirty water seeps through the seals.

LONG STORAGE



CAUTION

To avoid personal injury:

- Do not clean the excavator with the engine running.
- To avoid the danger of exhaust fume poisoning, do not operate the engine in a closed building without proper ventilation.
- When storing, remove the key from the starter switch to avoid unauthorized persons from operating the excavator and getting injured.
- Bring the excavator on a firm, flat, and level surface. Lower the attachments and dozer blade on the ground.

■ Should the Excavator be Stored for a Longer Period of Time, Observe Following Procedures:

1. The whole excavator should be cleaned thoroughly and in all cases stored indoors. If the excavator has to be kept outdoors, lay out wooden planks on even ground, place the excavator on the planks and cover completely.
2. Do an oil change and grease the excavator.
3. Heavily grease the visible section of the cylinder rods.
4. Remove the battery and store indoors.
5. If it is expected that the temperature will sink below the 0°C (32°F) mark, add anti-freeze or drain coolant completely.

IMPORTANT :

- Wash the excavator after stopping the engine.
If you wash the excavator while running the engine, splashing water gets into the air cleaner through its intake and cause engine damage.
Carefully, wash and do not splash water over the air cleaner while the engine is running.

■ Observe Following Procedures when the Machine is to be Operated after Long Storage.

1. Wipe off the grease from the hydraulic cylinder rods.
2. Turn on the engine and operate the attachments and the drive mechanisms under no load in order to circulate the hydraulic oil.
(If the machine is stored for longer than one month, do steps 1 and 2 once every month.)

Periodic replacement of important component parts

To ensure safety in operation, you are strongly requested to inspect and service the machine at regular intervals. For added safety, ask your KUBOTA dealer to replace the following important component parts.

These parts are prone to degradation in material or subject to wear and tear with time. It is difficult to judge how much they have been affected at regular inspection. It is therefore necessary to replace them with new ones, whether wear is visible or not after a specified time of use.

If any of them is found to be worn before the specified use, they must be repaired or replaced the same as other parts.

If any of the hose clamps are found deformed or cracked, the hose clamps must also be replaced.

For the hydraulic hoses other than the ones to be replaced periodically, inspect them for the following points. If found loose or very worn, tighten and / or replace the hose.

When replacing the hydraulic hoses, change their O rings and sealing components with new ones.

For replacement of the important parts, contact your KUBOTA dealer.

- At the following periodic inspections, check the fuel hoses and hydraulic hoses as well.

Inspection Interval	Check points
Daily Checks	Oil leak at fuel and hydraulic hose connections and points
Every month	Oil leak at fuel and hydraulic hose connections and points Damages at fuel and hydraulic hose (cracks, chafing)
Every year	Oil leak at fuel and hydraulic hose connections and points Interference, deformation, degradation, twist and other damages (cracks, chafing) of fuel and hydraulic hoses

List of important component parts

No.	Component parts	Used place	Q'ty	Period
1	Fuel hose	Fuel tank - Water separator	1	Every 2 years or 4000 hours
		Water separator - Fuel filter	1	
		Fuel filter - Fuel pump	1	
		Fuel pump - Fuel nozzle	1	
		Fuel nozzle - Fuel tank	2	
2	Hydraulic hose (suction)	Tank - Main pump	1	
3	Hydraulic hose (delivery)	Main pump - Control valve	3	
		Main pump - Pilot filter	1	
		Pilot filter - Change valve	2	
4	Hydraulic hose (Boom cylinder)	Control valve - Boom cylinder	*2	
5	Hydraulic hose (Arm cylinder)	Control valve - Pipe, Boom	*2	
		Pipe, Boom - Arm cylinder	*2	
6	Hydraulic hose (Bucket cylinder)	Control valve - Pipe, Boom	*2	
		Pipe, Boom - Bucket cylinder	*2	
7	Hydraulic hose (Swing cylinder)	Control valve - Swing cylinder	2	
8	Hydraulic hose (Dozer cylinder)	Control valve - Rotary joint	2	
		Rotary joint - Pipe	2	
		Pipe - Dozer cylinder	2	
9	Hydraulic hose (Service port)	Control valve - Pipe, Boom	*2	
		Pipe, Boom - Pipe, Boom	*2	
		Pipe, Boom - Pipe, Arm	*2	
10	Hydraulic hose (Swivel motor)	Control valve - Swivel motor	2	

To prevent serious damage to the hydraulic system, use only a KUBOTA genuine hydraulic hose.

(Since especially * marks are super wear resistance hoses, please surely use a KUBOTA genuine hydraulic hose.)

RECOMMENDED OILS

IMPORTANT :

- Before delivery, the hydraulic oil used was an ISO 46 viscosity grade.
- Use engine oil API service classification CD, CE or CF.
- Use SAE 90 (API, CLA/GL5) as drive unit oil for all seasons.

	Application	Viscosity	Shell	Mobil	Exxon	MIL-Standard
Engine oil	In winter or by low temperatures	SAE 10W	Shell Rotella T10W Shell Rimula 10W	Mobil Delvac 1310	XD-3 10W XD-3 Extra 10W	MIL-L-2104C MIL-L-2104D
		SAE 20W	Shell Rotella T20W-2 Shell Rimula 20W-2	Mobil Delvac 1320	XD-3 20W-20 XD-3 Extra 20W-20	
	In summer or by high ambient temperatures	SAE 30	Shell Rotella T30 Shell Rimula 30	Mobil Delvac 1330	XD-3 30 XD-3 Extra 30	
		SAE 40	Shell Rotella T40 Shell Rimula 40	Mobil Delvac 1340	XD-3 40 XD-3 Extra 40	
		SAE 50	Shell Rimula 50	Mobil Delvac 1350		
All- Season engine oil	Multi-purpose	Shell Rotella T15W-40		XD-3 15W-40 XD-3 Extra 15W-40		
Gear oil	In winter or by low temperatures	SAE 75		Mobilube HD80W-90		MIL-L-2105C
			Shell Oil S8643			
	In summer or by high ambient temperatures	SAE 80		Mobilube HD80W-90		MIL-L-2105 MIL-L-2105C MIL-L-2105C MIL-L-2105C
			Shell Spirax HD80W			
		SAE 90		Mobilube46		
			Shell Spirax HD90	Mobilube HD80W-90		
All- weather gear oil	Multi-purpose	SAE 140		Mobilube HD85W-140		
			Shell Spirax HD140	Mobilube HD80W-140		
Hydraulic oil	In winter or by low temperatures	ISO 32	Shell Tellus T32	Mobil DTE-Oil 13	NUTO H32	
		ISO 46	Shell Tellus T46	Mobil DTE-Oil 15	NUTO H46	
	In summer or by high ambient temperatures	ISO 68	Shell Tellus T68	Mobil DTE-Oil 16	NUTO H68	
Grease			Shell Alvania EP2	Mobilux EP2	BEACON Q2	
Fuel			Light oil No. 2-D (ASTM D975)			
Fuel under -5°C (+23°F)			Light oil No. 1-D (ASTM D975)			

MAIN DIMENSIONS

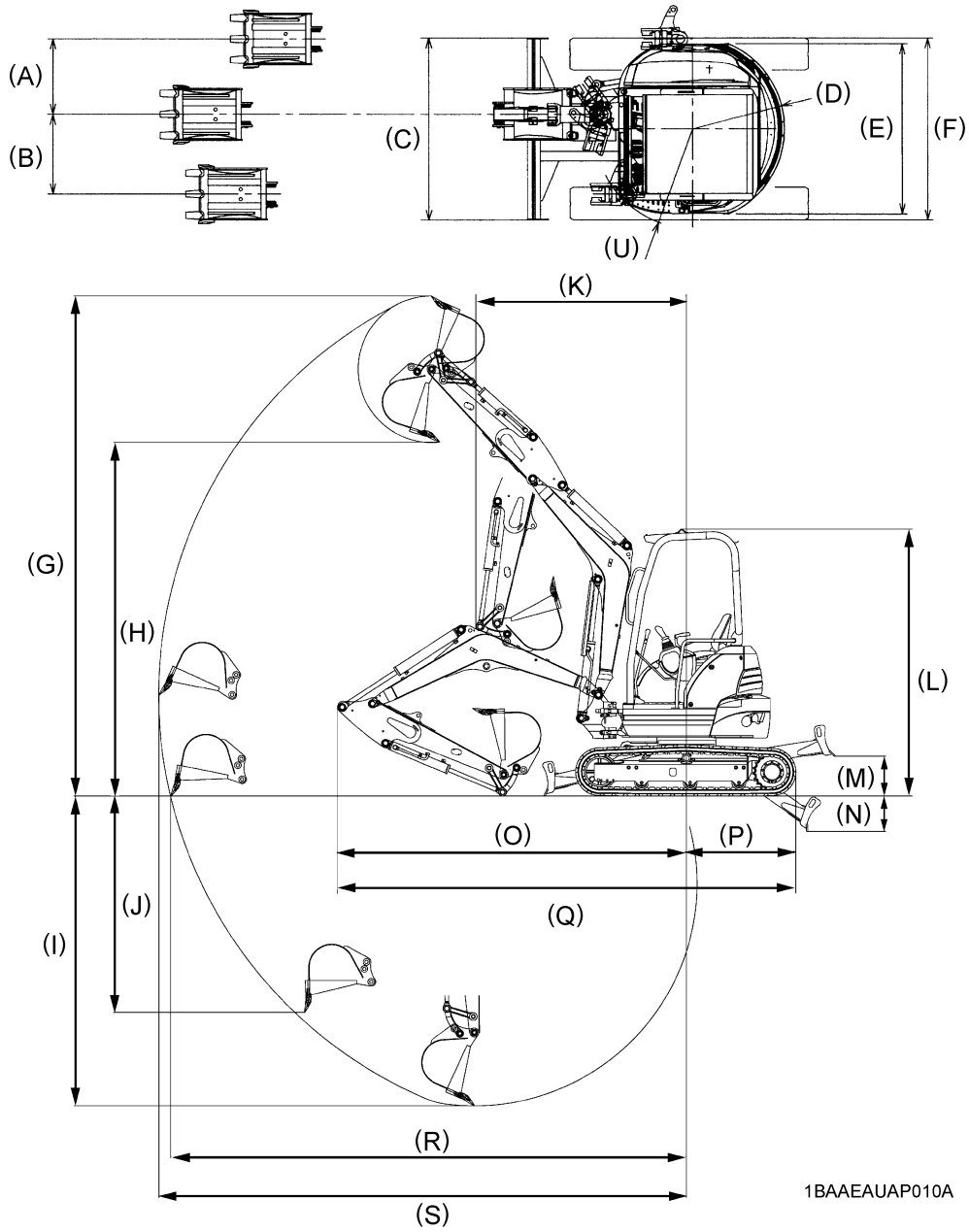

1BAAEUAP010A

mm

	(A)	(B)	(C)	(D)	(E)	(F)	(G)	(H)	(I)	(J)
U25 CANOPY	590	620	1500	760	1300	1500	4530	3200	2810	1960
	(K)	(L)	(M)	(N)	(O)	(P)	(Q)	(R)	(S)	(U)
U25 CANOPY	1900	2420	360	320	3160	990	4150	4670	4780	800

LIFTING CAPACITY

- The lifting capacities are based on ISO 10567 and do not exceed 75% of the static tilt load of the machine or 87% of the hydraulic lifting capacity of the machine.
- The strokes are as follows.
 - The load point corresponds to the front bolt part of the arm.
 - The machine positions are (i) over - front (Blade down), (ii) over - front (Blade up), and (iii) over - side.
 - The operating cylinder is the boom cylinder.
- The bucket of the excavator, the hook, the sling and other lifting accessories are taken into consideration for the loads.
Machine conditions:
No bucket, all others according to the standard regulations.



WARNING

To avoid personal injury or death:

- No loads greater than those values mentioned in the lifting capacity tables are to be lifted.
- No loads greater than 1 ton are to be lifted when no safety devices are attached to boom and dozer blade cylinders.
- The values mentioned in the table are valid only on even, hard grounds. When lifting on soft ground, the machine can tip over due to the load being concentrated only on one side of the machine.
- The table values are calculated at the end of the arm without the bucket. In order to find the allowable loads for machines with bucket, the bucket weight must be subtracted from the values in the table.

NOTE :

- In this manual, the machine's lifting capacity is discussed, but it does not mean that it is recommended to use the machine for lifting jobs.
- It is specified in Item 3.4 of ISO 10567:1992 that the following devices must be additionally installed if a hydraulic excavator with the rated lift load of over 1,000 kg at its minimum lifting radius or the tilting moment of over 40,000 N-m is used for lifting loads.
 - (1) Lifting hook
 - (2) Acoustic alarm or warning lamp for the operator when the rated load or the corresponding tilting moment has been exceeded.
 - (3) Boom descending control device conforming to ISO 8643:1997

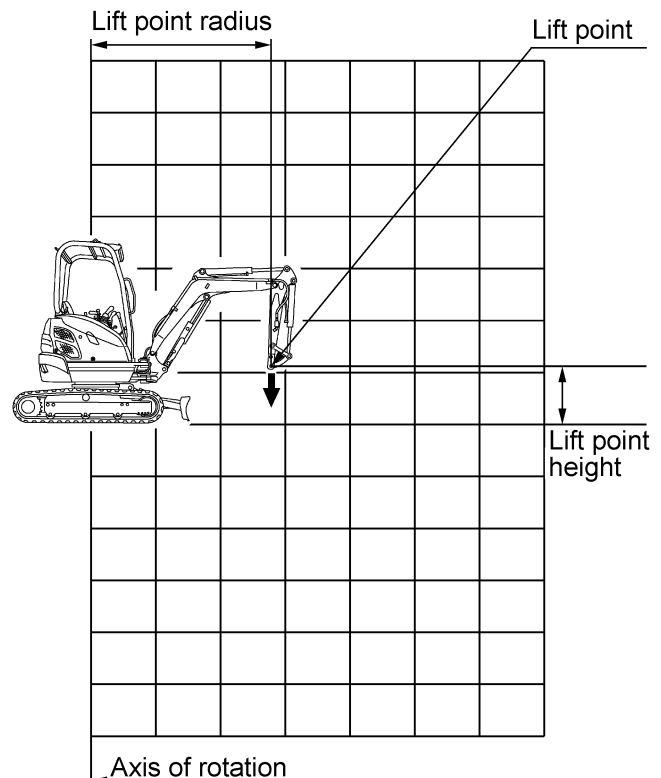

1BAABAAAP411A

U25 LONG ARM
RUBBER TRACK
ROPS CANOPY

LIFTING CAPACITY OVER-FRONT BLADE DOWN

kN (kg)

LIFT POINT HEIGHT (m)	LIFT POINT RADIUS (m)									
	0.0	0.5	1.0	1.5	2.0	2.5	3.0	3.5	4.0	4.5
GL	3.5									
	3.0						3.6 (370)			
	2.5						3.6 (370)	3.7 (380)		
	2.0					4.1 (420)	3.9 (400)	3.8 (390)		
	1.5				6.5 (670)	5.2 (530)	4.5 (450)	4.0 (410)	3.8 (390)	
	1.0				9.2 (930)	6.4 (650)	5.1 (520)	4.4 (450)	3.9 (400)	
	0.5				10.8 (1100)	7.3 (740)	5.6 (570)	4.6 (470)	4.0 (410)	
	0.0			6.2 (630)	11.1 (1130)	7.7 (790)	5.9 (600)	4.8 (490)		
	-0.5		7.8 (790)	9.9 (1020)	10.7 (1090)	7.6 (780)	5.9 (600)	4.6 (470)		
	-1.0		11.4 (1160)	14.4 (1470)	9.6 (980)	7.0 (720)	5.4 (550)	3.9 (400)		
	-1.5		15.9 (1620)	11.2 (1140)	7.7 (790)	5.7 (580)	4.0 (410)			
	-2.0			6.2 (630)	4.5 (460)					

LIFTING CAPACITY OVER-FRONT BLADE UP

kN (kg)

LIFT POINT HEIGHT (m)	LIFT POINT RADIUS (m)									
	0.0	0.5	1.0	1.5	2.0	2.5	3.0	3.5	4.0	4.5
GL	3.5									
	3.0						3.6 (370)			
	2.5						3.6 (370)	3.4 (340)		
	2.0					4.1 (420)	3.9 (400)	3.3 (340)		
	1.5				6.5 (670)	5.2 (530)	4.2 (430)	3.3 (340)	2.7 (270)	
	1.0				7.8 (790)	5.4 (550)	4.1 (420)	3.2 (330)	2.6 (270)	
	0.5				7.5 (770)	5.3 (540)	4.0 (410)	3.2 (330)	2.6 (270)	
	0.0			6.2 (630)	7.4 (750)	5.2 (530)	3.9 (400)	3.1 (320)		
	-0.5		7.8 (790)	9.9 (1020)	7.4 (750)	5.1 (520)	3.9 (400)	3.1 (320)		
	-1.0		11.4 (1160)	12.9 (1310)	7.4 (750)	5.1 (520)	3.9 (400)	3.2 (320)		
	-1.5		15.9 (1620)	11.2 (1140)	7.5 (760)	5.2 (530)	4.0 (400)			
	-2.0			6.2 (630)	4.5 (460)					

LIFTING CAPACITY OVER-SIDE

kN (kg)

LIFT POINT HEIGHT (m)	LIFT POINT RADIUS (m)									
	0.0	0.5	1.0	1.5	2.0	2.5	3.0	3.5	4.0	4.5
GL	3.5									
	3.0						3.6 (370)			
	2.5						3.6 (370)	2.8 (290)		
	2.0					4.1 (420)	3.6 (370)	2.8 (290)		
	1.5				6.5 (670)	4.6 (470)	3.5 (360)	2.8 (280)	2.2 (230)	
	1.0				6.2 (640)	4.5 (460)	3.4 (350)	2.7 (280)	2.2 (230)	
	0.5				6.0 (610)	4.3 (440)	3.3 (340)	2.7 (270)	2.2 (220)	
	0.0			6.2 (630)	5.9 (600)	4.2 (430)	3.3 (330)	2.6 (270)		
	-0.5		7.8 (790)	9.6 (980)	5.9 (600)	4.2 (430)	3.2 (330)	2.6 (270)		
	-1.0		11.4 (1160)	9.7 (990)	5.9 (600)	4.2 (430)	3.2 (330)	2.6 (270)		
	-1.5		15.9 (1620)	9.8 (1000)	6.0 (610)	4.2 (430)	3.3 (340)			
	-2.0			6.2 (630)	4.5 (460)					